



Installation Manual  
Low Level HL & VL

## Contents

Symbols.....	3
General warnings .....	3
Safety requirements for assembly and first use .....	3
Terms and conditions .....	3
Guidelines .....	4
Fixing material to the construction .....	4
Trackset Assembly .....	4
Panel Assembly .....	5
System overview and build in requirements .....	5
Application range .....	5
Notes .....	6
Assembly .....	7
First use .....	33
Handover .....	33
Electric operator (optional) .....	33
Control unit settings .....	33
Disassembly .....	33
Warnings .....	33
Procedure .....	33
Disposal .....	34
Maintenance .....	34
Warnings .....	34
Replacement of Parts .....	35
Supplier .....	35

## Symbols



Danger Sign: Important (safety) instructions



Information Sign, Indication Sign: Hint or Clue



Book Sign: Additional manual



Eye Sign: Look to / Check



DPD Sign: Door Processing Document



Hand Sign: Operation by hand



Chain Hoist Sign: Operation by Chain Hoist



E. Operator Sign: Operation by Electric Operator

## General warnings

This manual has been prepared for use by qualified persons and therefore not by trainees or “do it yourselfers”. The persons how assembly, disassembly, maintain or put the door system into operation need to careful read, understand and follow this manual. To avoid severe personal injury, carefully read and observe all indications and warnings in this manual.

- This manual describes the assembly, disassembly and maintenance of your Industrial Door System; this may be supplemented by other manuals, for instance the spring break device manual, cable break device and operator manual (if applicable.)
- The Industrial Door System has been designed in accordance with the latest European standards; however you have to check yourself whether this standard corresponds with the local national standard.
- All measurements are in millimeters unless otherwise specified.
- After installation ensure that the CE marking label has been completed and attached.
- Keep this manual in a safe place, near to the Industrial door.
- Subject to technical changes, without written notice.

## Safety requirements for assembly and first use

- This Industrial Door System may only be mounted, connected and put into operation and maintained by qualified persons.
- Make sure that the power is switched off and remains switched off while electrical work is carried out!
- Never bridge safety devices!
- Adding or leaving out parts can affect the door operation in a negative way and therefore the safety of the installed sectional door. This is therefore strongly discouraged!
- Some parts can contain sharp edges: use protective gloves.
- All references to the door/component handing within this manual is always as viewed from inside looking out.
- Never use the Industrial Door System in case of a visual damage, especially cables and safety devices.
- When performing assembly/maintenance, always wear at least gloves and safety boots and during drilling/cutting wear safety goggles!
- Make sure that you can always perform your work in a stable environment.
- Secure the assembly/maintenance site with safety ribbon to keep others at a distance.
- Maintenance must only be performed by a qualified installation company and/or qualified persons.
- Make sure there is enough light.
- Only use appropriate tools, especially when tensioning the torsion springs.

## Terms and conditions

Our general conditions of delivery and payments are applicable on all our offers, agreements or subsequent revisions. A copy of our terms and conditions are available on request or can be downloaded from our website: [www.doco-international.com](http://www.doco-international.com)

## Guidelines

DOCO International had carried out the "Product Test" of this door (Initial Type Testing = ITTr) by the SP institute in Sweden, known as Notified Body No. 0402.

Documents regarding this ITTr can, in consultation with DOCO, be transferred to the company which produces the door. This is necessary to complete the Technical File.

NOTE: CE-approved only using the correct DOCO-components.

It is the responsibility of the installation company to ensure that the chosen E-operator and panels are according to the product standard EN13241-1 and have carried out the necessary ITTr.

If a wicket door is to be installed, it is the responsibility of the installation company to ensure that the complete door conforms to the product standard EN13241-1 and have carried out the necessary ITT.

## Fixing material to the construction



The necessary fixings to ensure the Industrial Door System to the building and/or ceiling, are not included!

It is the responsibility of the installation company to make sure that the building structure is safe/strong enough, to accept the door and its fixings.

The installer is also responsible for using the correct fixing materials on the right foundation (stone, concrete, steel, wood). In the image section there will be therefore no specification included.

Doorweight\* for roofload: 510 N/m<sup>2</sup>  
Using doorblads between 7-14 kg/m<sup>2</sup>

## Trackset assembly

When you received a trackset kit you can skip this section.

When you build your own trackset follow next construction guideline:



### Drilling:

Use M8 bolt (14010 or 14023) and nuts (14022 or 14013) every 650 mm (max.) between below connections, predrill Ø8,5mm:

Vertical Trackset: connection between, Vertical Angle 290030-series and Track 22000-series.

Horizontal Trackset: connection between, Curve 215091-series and C-track 220016-series.

Connection between vertical angle 290030-series and connection brackets 235300 - 235307

Use 1 M8 bolts / nuts (as above) between track and connection bracket and 1 M8 bolts / nuts (as above) spread out between Vertical angle and connection bracket.

*More information see: Technical Production Book*



### Riveting:

Minimum rivet size: 5mm, every 650 mm (max.) between below connections.

Rivets need to fixed in accordance with the instructions / manual of the rivet equipment.

Vertical Trackset: connection between, Vertical Angle 290030-series and Track 22000-series.

Horizontal Trackset: connection between, Curve 215090-series and C-track 220016-series.

Connection between vertical angle 290030-series and connection brackets 235300 - 235307.

Use 1 rivet (as above) between track and connection bracket and 2 rivets (as above) spread out between Vertical angle and connection bracket.

*More information see: Technical Production Book*



## Panel assembly



The panels need to be assembled according the *Industrial Panel Assembly Manual*

## System Overview and build in requirements



See *Industrial Track Systems* document for system drawings, build in requirements and required free running space of the industrial door.

## Application Range

This hardware set has been developed for commercial use



**HL**

- Maximum width 6500 mm [DW]
- Height min 2500, max 6000 mm [DH]
- High lift: Min 1700, max 4100 [HL]
- $DH+HL < 9947\text{mm}$
- Weight door leaf maximum: 350 kg
- Max. temperature range outside\*:  $-20^{\circ}\text{C}$  until  $+50^{\circ}\text{C}$
- Relative humidity: 5-90%



**VL**









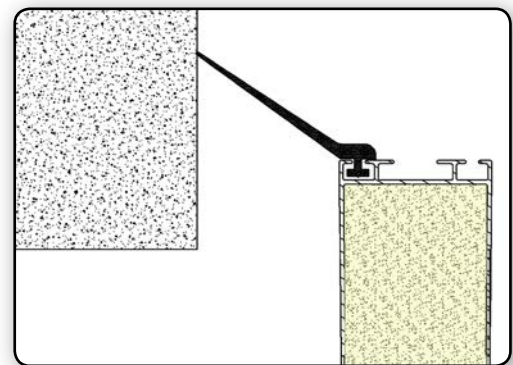
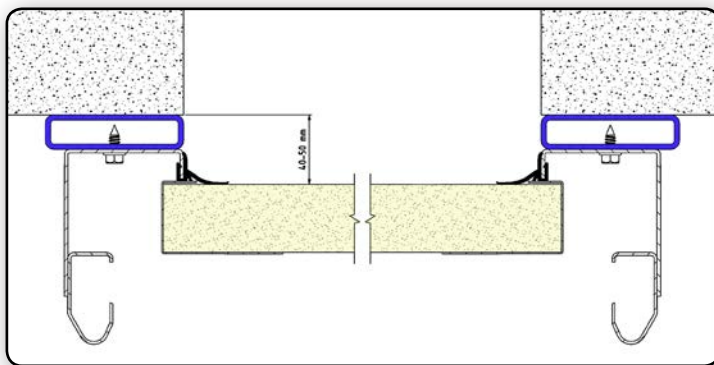

- Maximum width 6500 mm
- Height min 2500, max 5600 mm
- Weight door leaf maximum: 350 kg
- Max.temperature range outside\*:  $-20^{\circ}\text{C}$  until  $+50^{\circ}\text{C}$
- Relative humidity: 5-90%

\* Big differences in temperature between the inside and outside can cause deflection in the panel sections (bi-metal effect). In particular dark colored panels are susceptible to this problem and should be avoided. Care should be taken during manual handling as there is a big risk of damage.

Advised:

Use a frame to prevent damage to the door blade, when using doors  $DW > 5000$  with dark color panels.

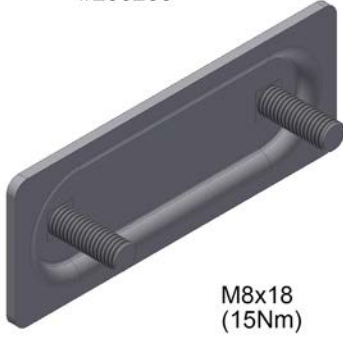

<p><b>A</b> #14023 (13Nm) M8x17</p> 	<p><b>B</b> #14024 (13Nm) M8x10</p> 	<p><b>C</b> #14022 (13/15 Nm) M8</p> 	<p><b>D</b> #14099 (35Nm) M10 - DIN 985</p> 
<p><b>E</b> #14020, L=16 #150002, L=25 #14017, L=35 (10Nm) Ø 6.3</p> 	<p><b>F</b> #150118 (18Nm) M8x25</p> 	<p><b>G</b> #150121 (35Nm) M10x25</p> 	<p><b>H</b> #235201 M8x15 (15Nm)</p> 
<p><b>I</b> #235205 M8x18 (15Nm) 32</p> 		<p><b>J</b> #235200 M8x18 (15Nm)</p> 	<p><b>K</b> #235203 M8x18 (15Nm) 43</p> 

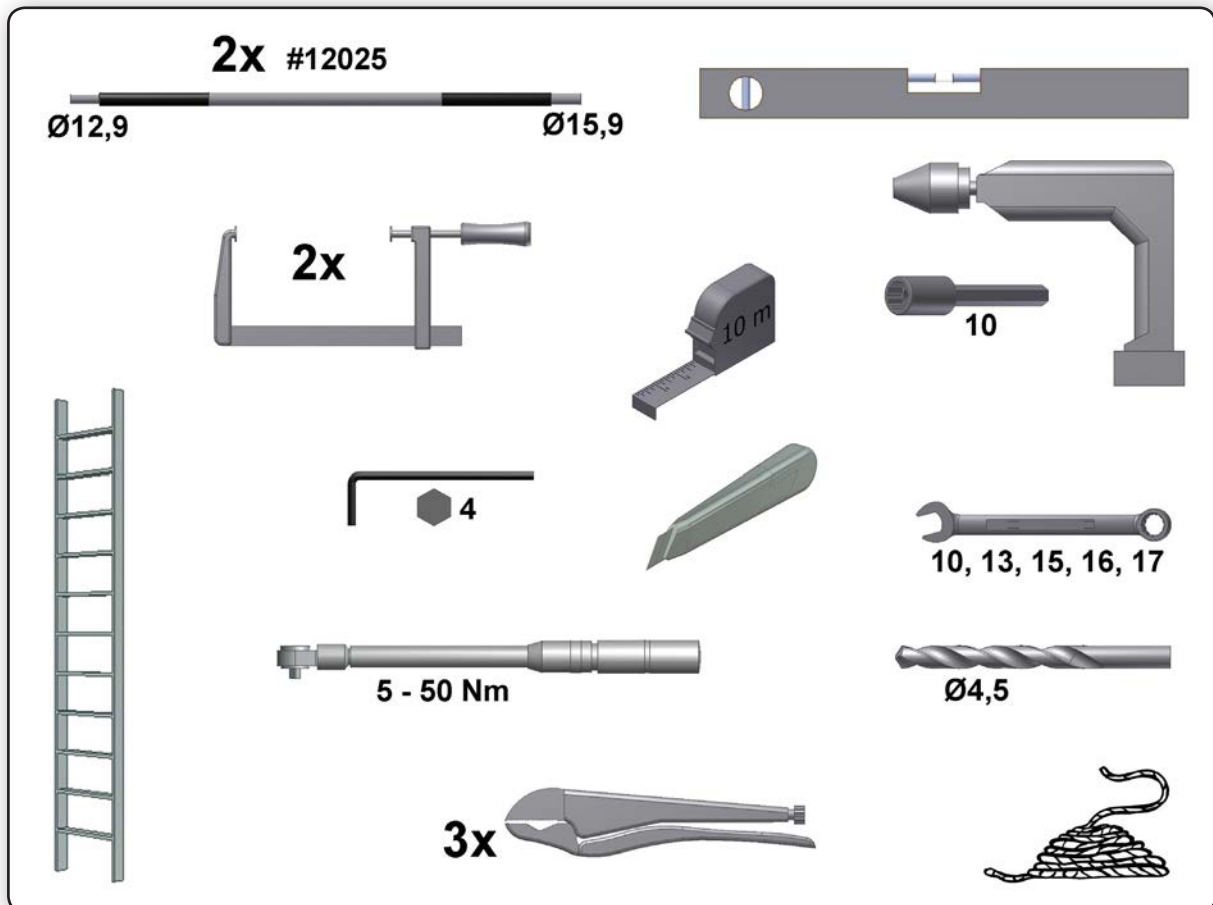

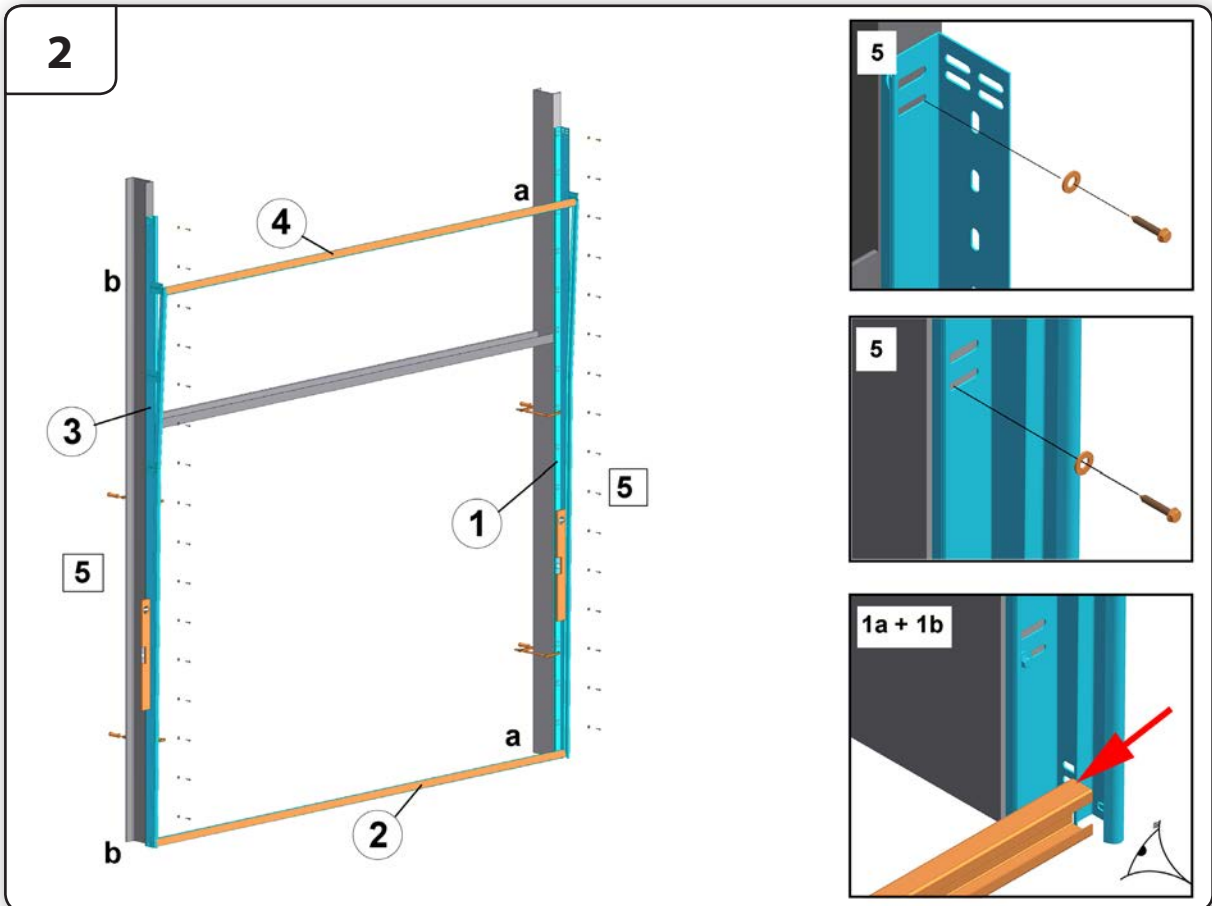
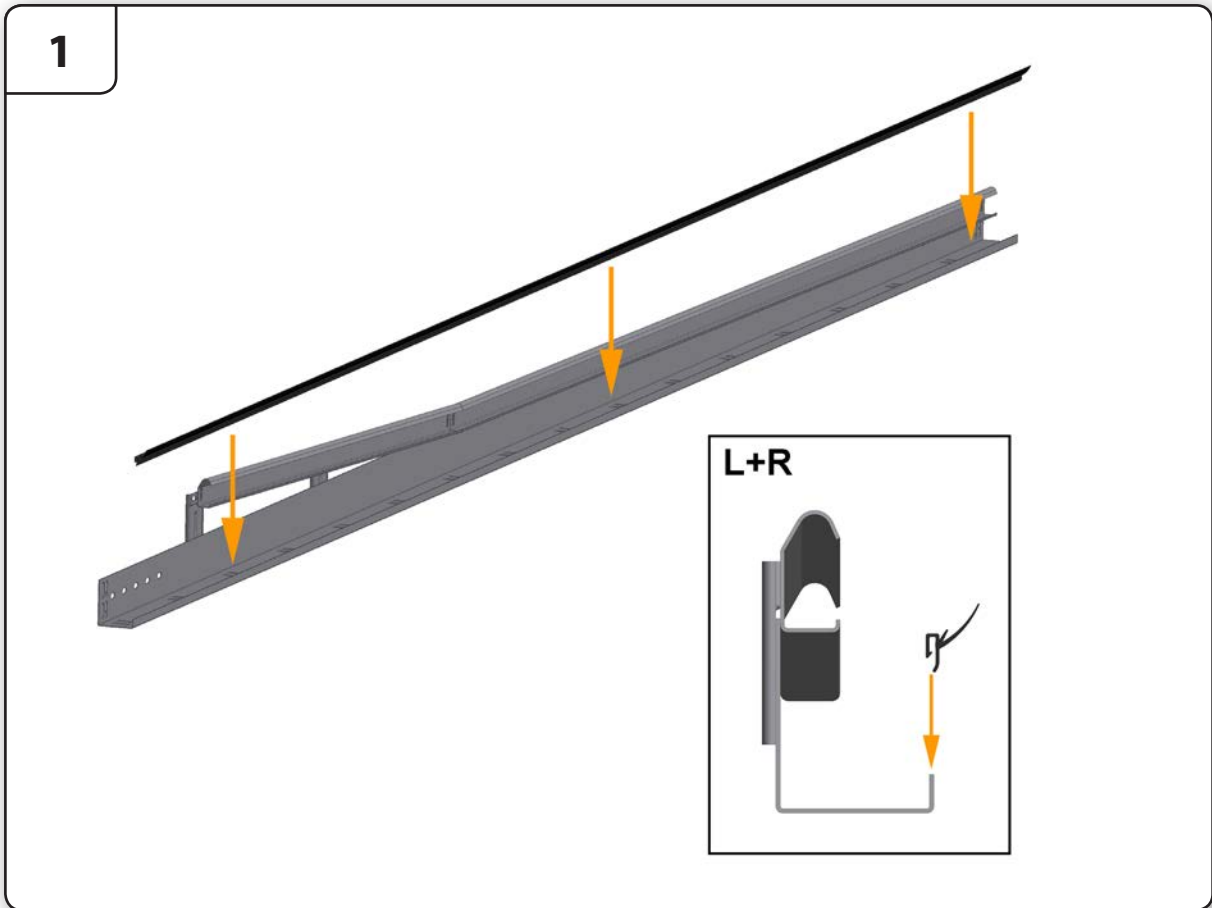

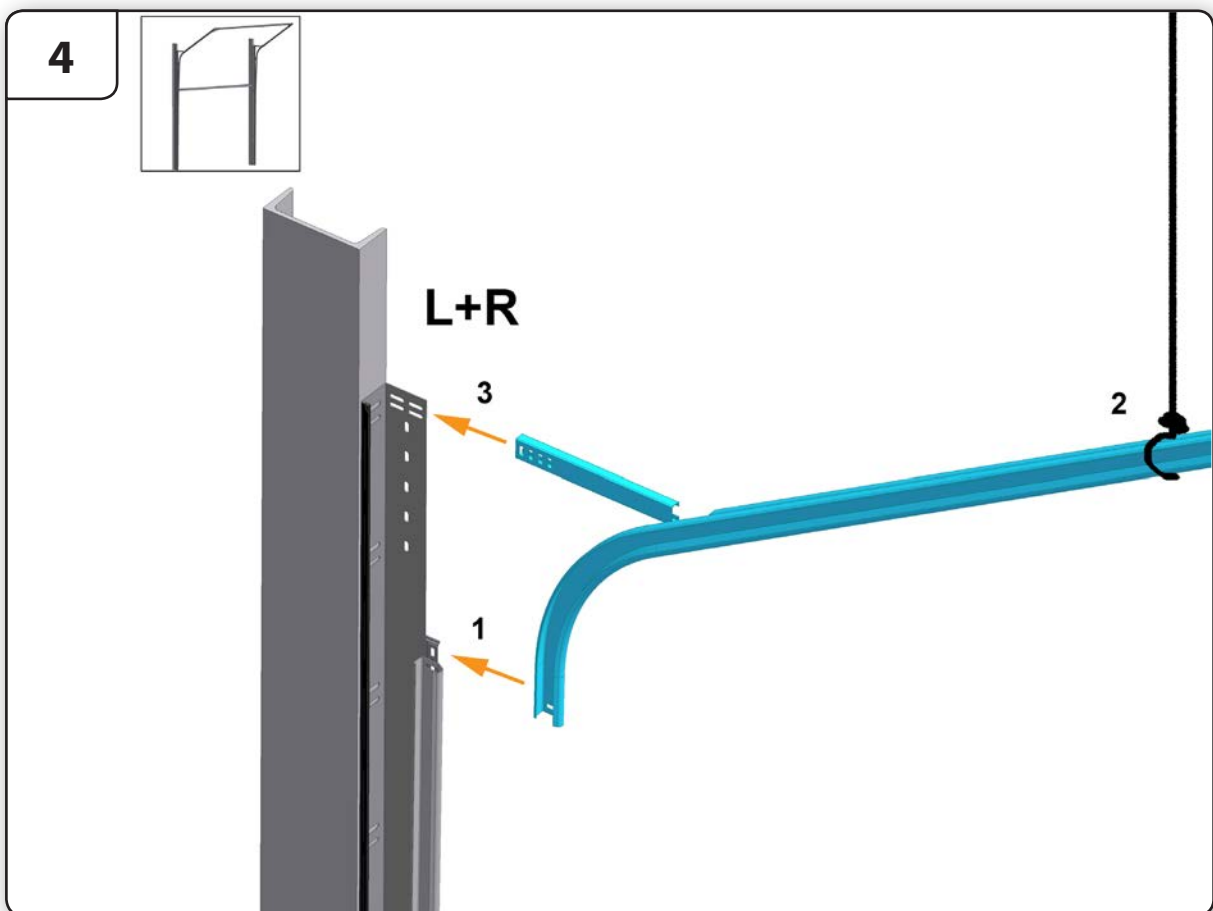
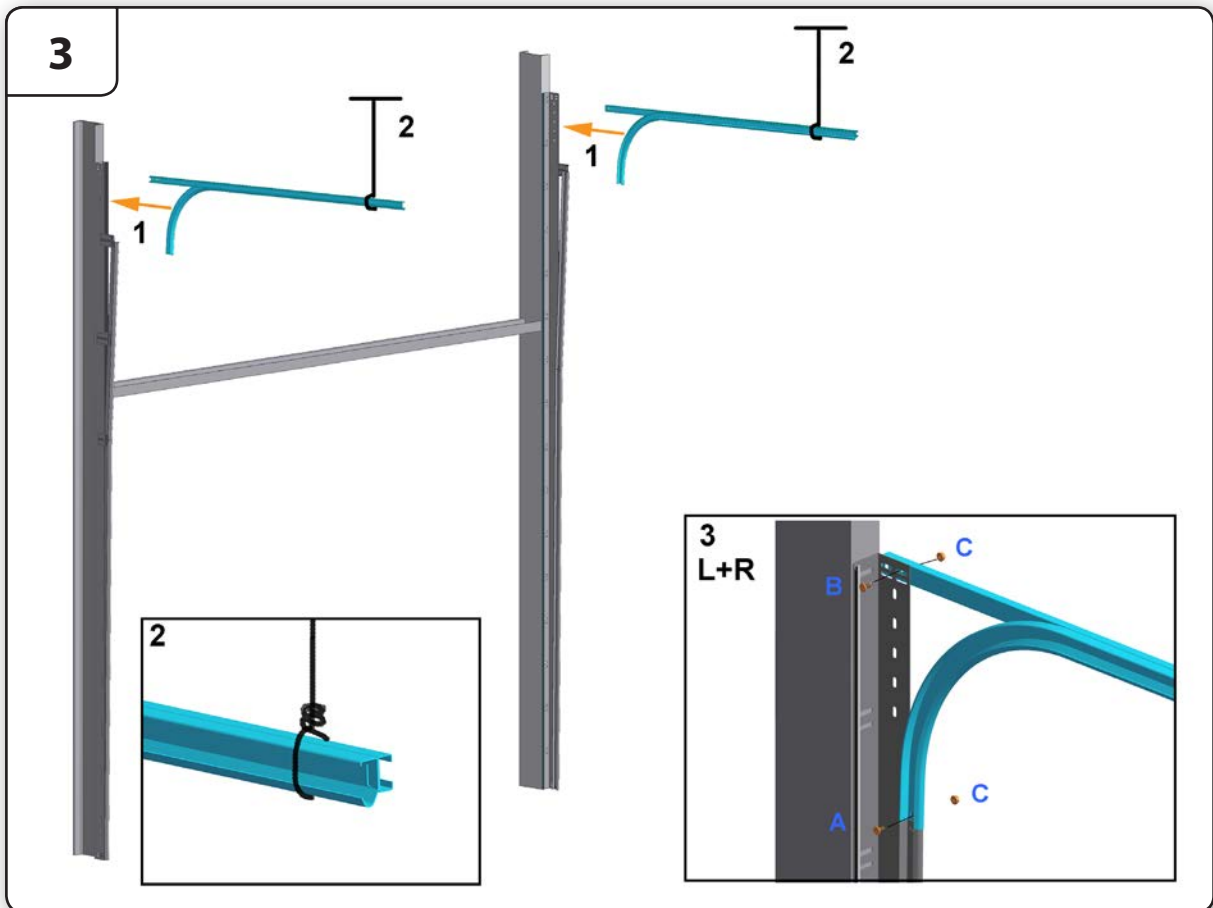

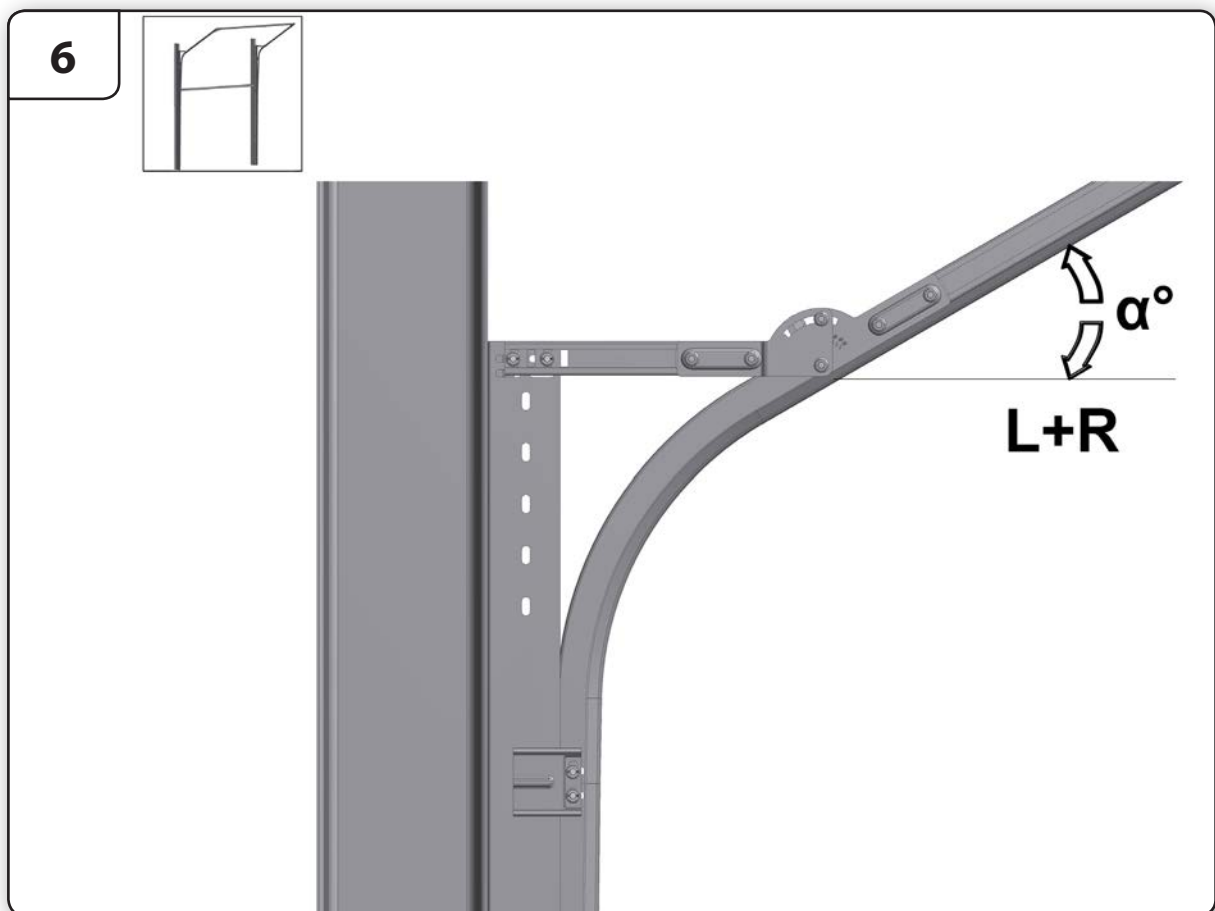
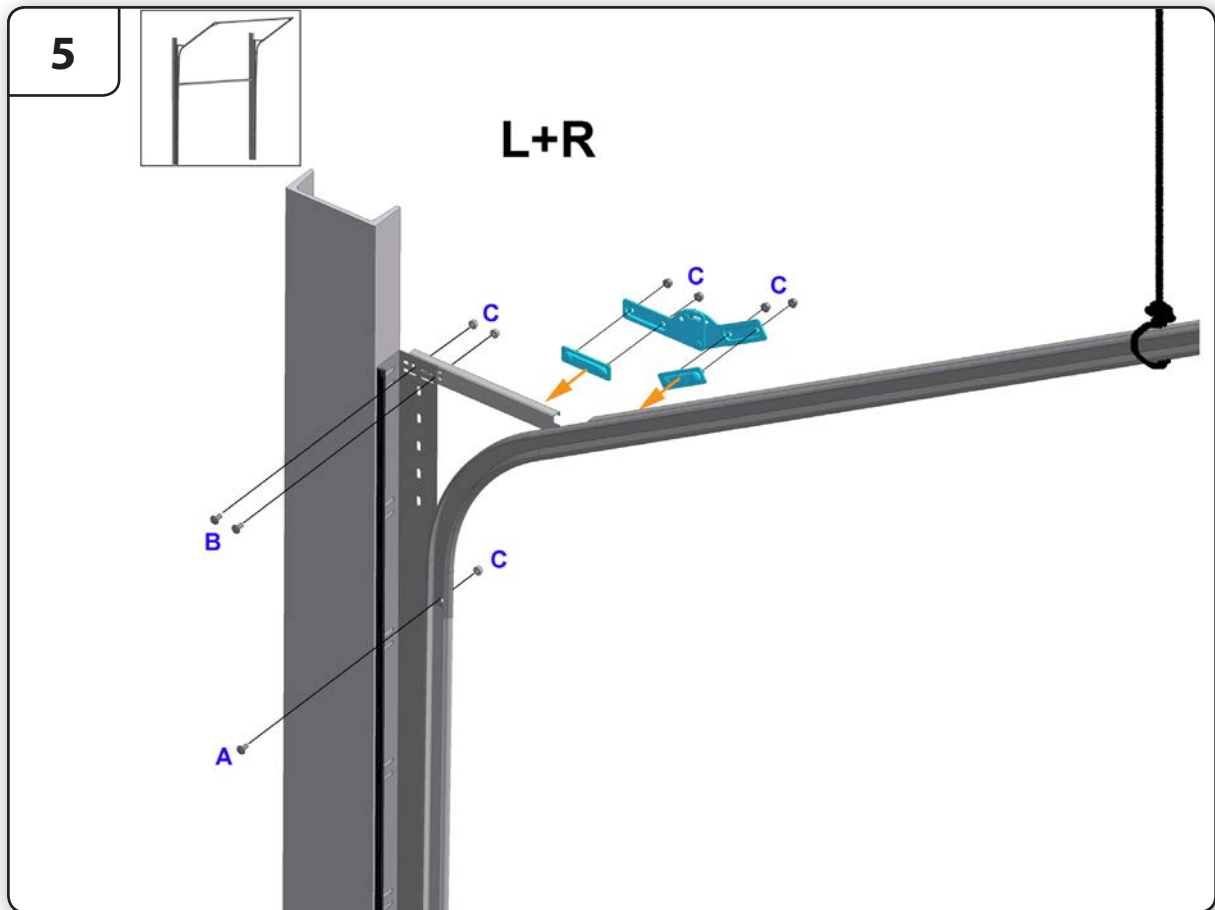

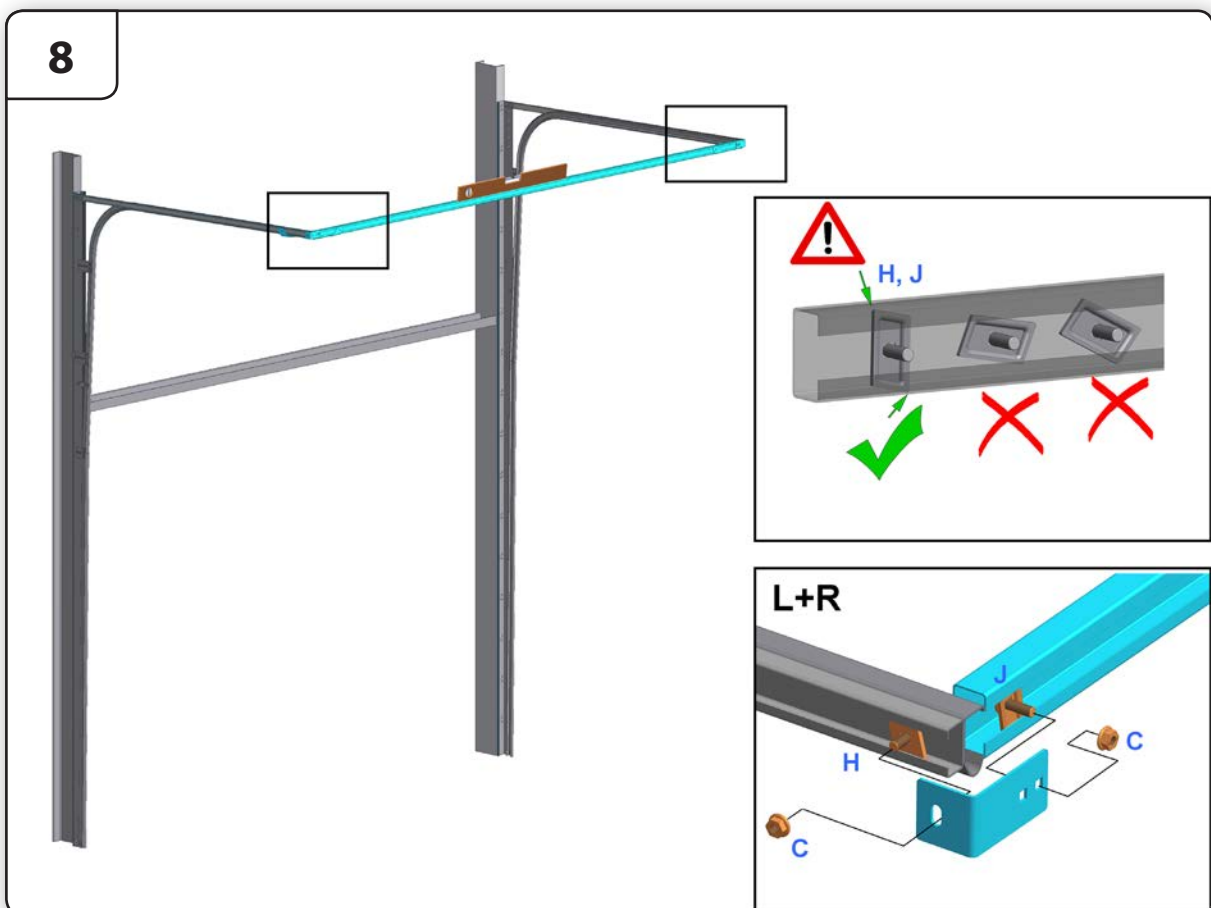
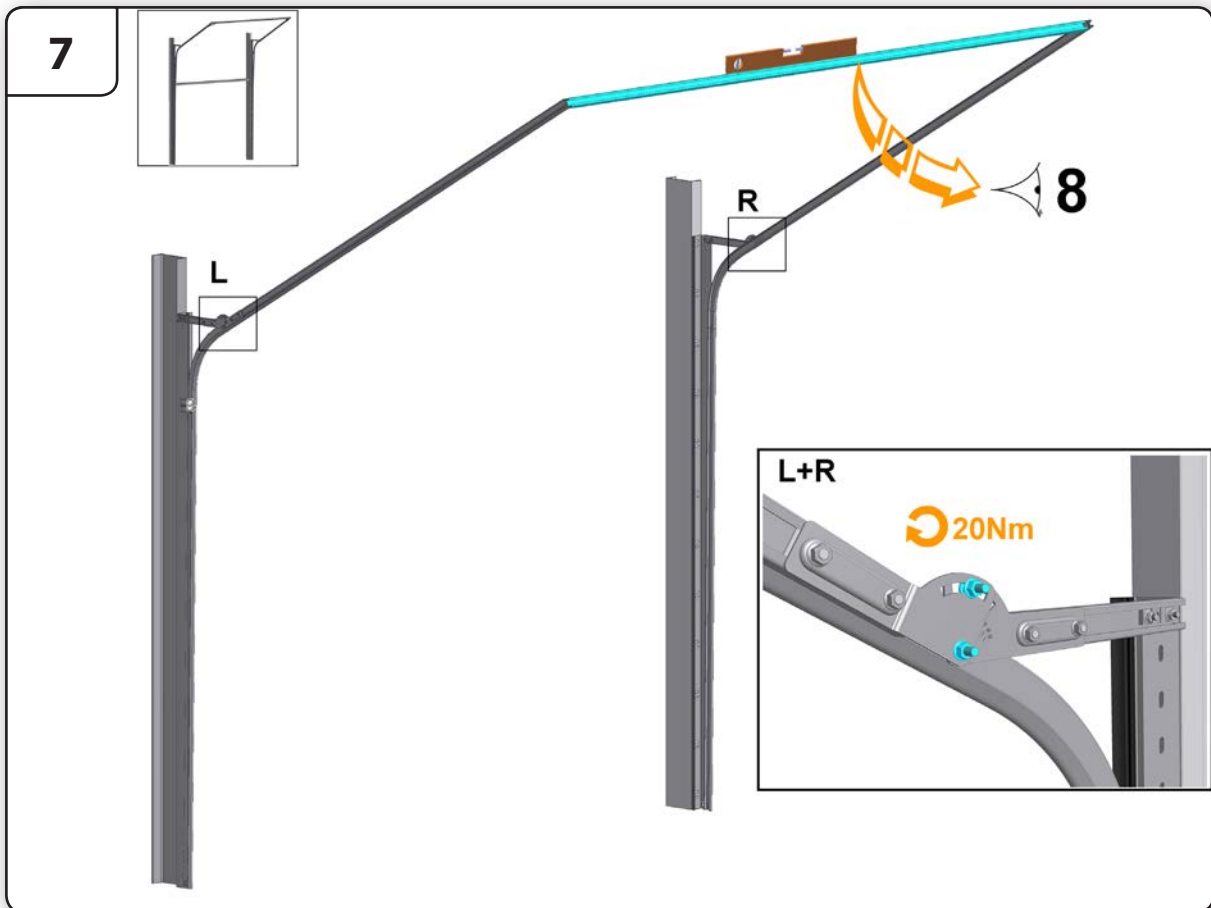

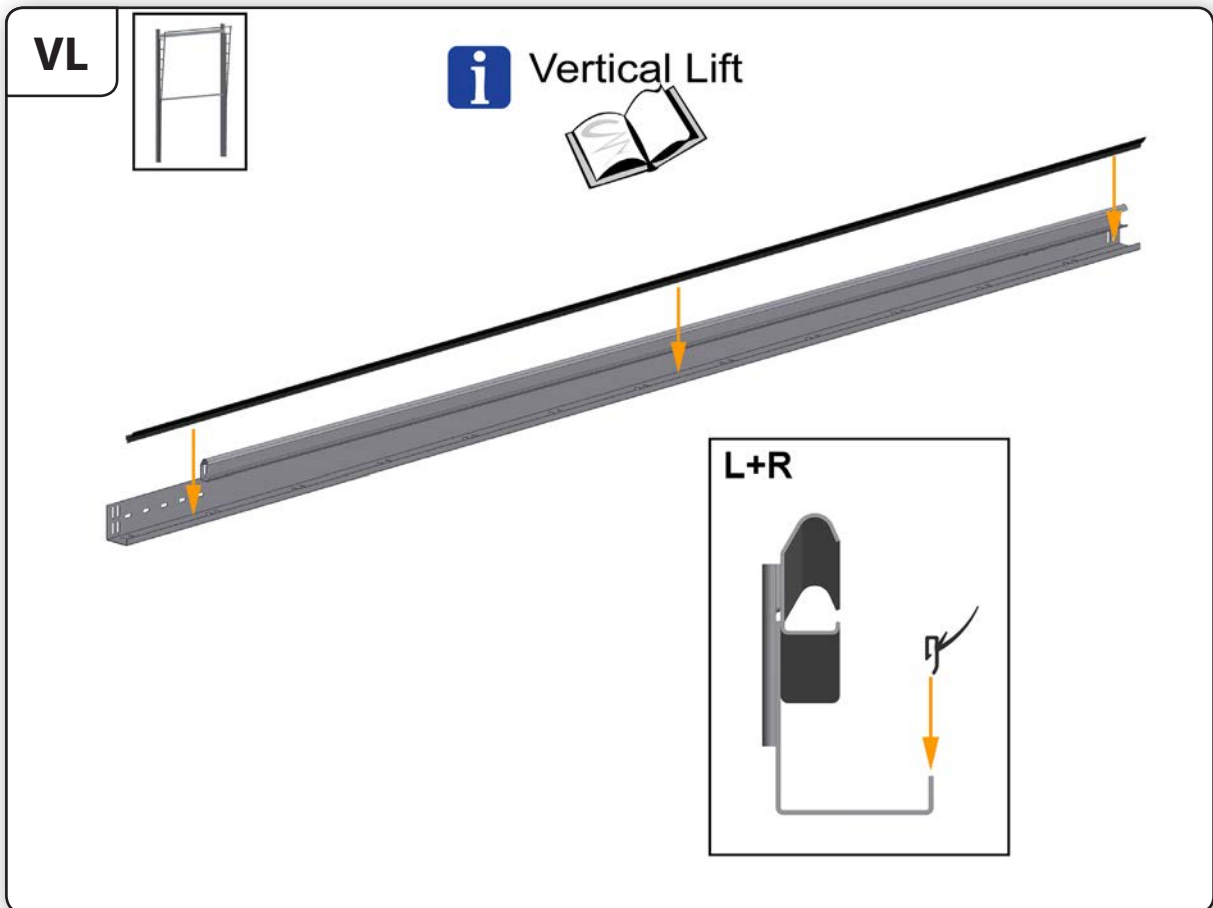
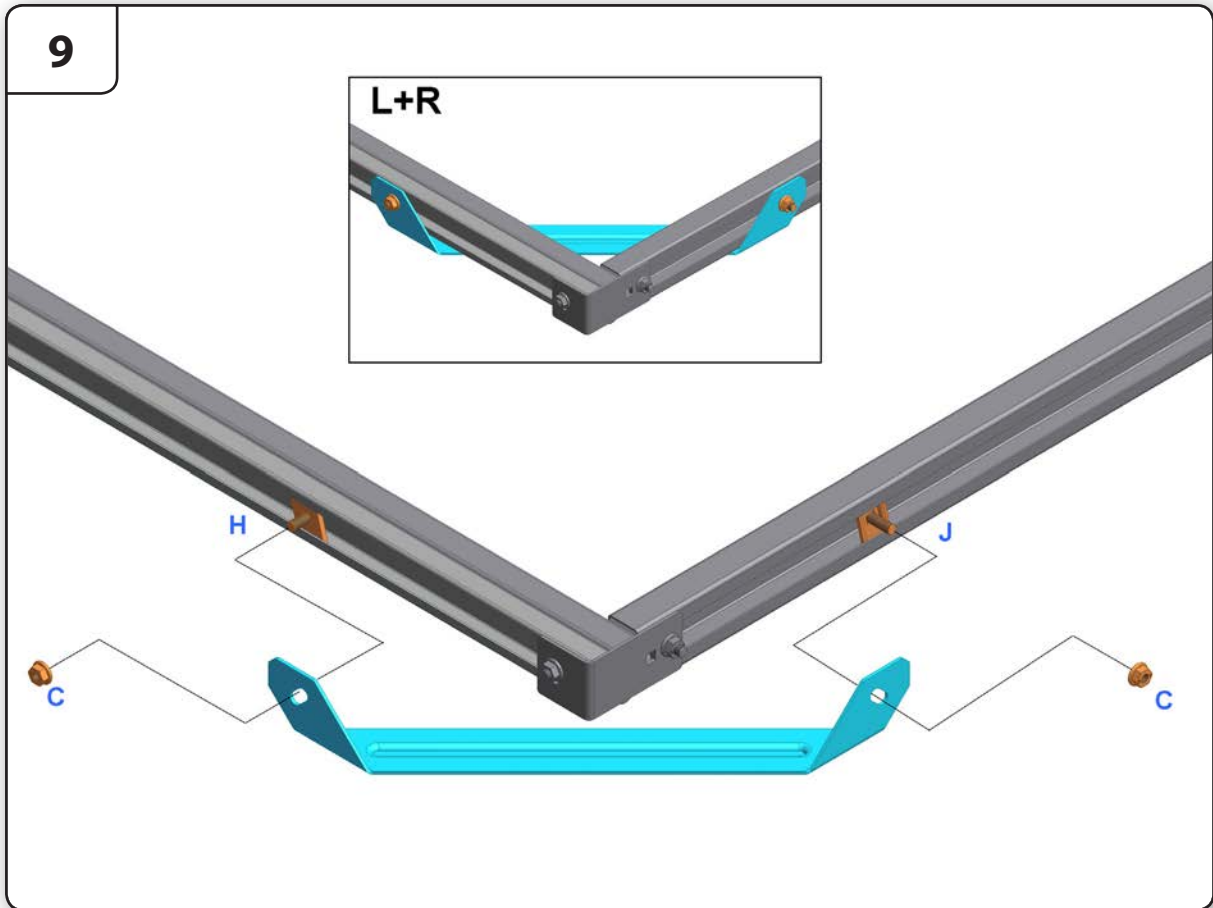

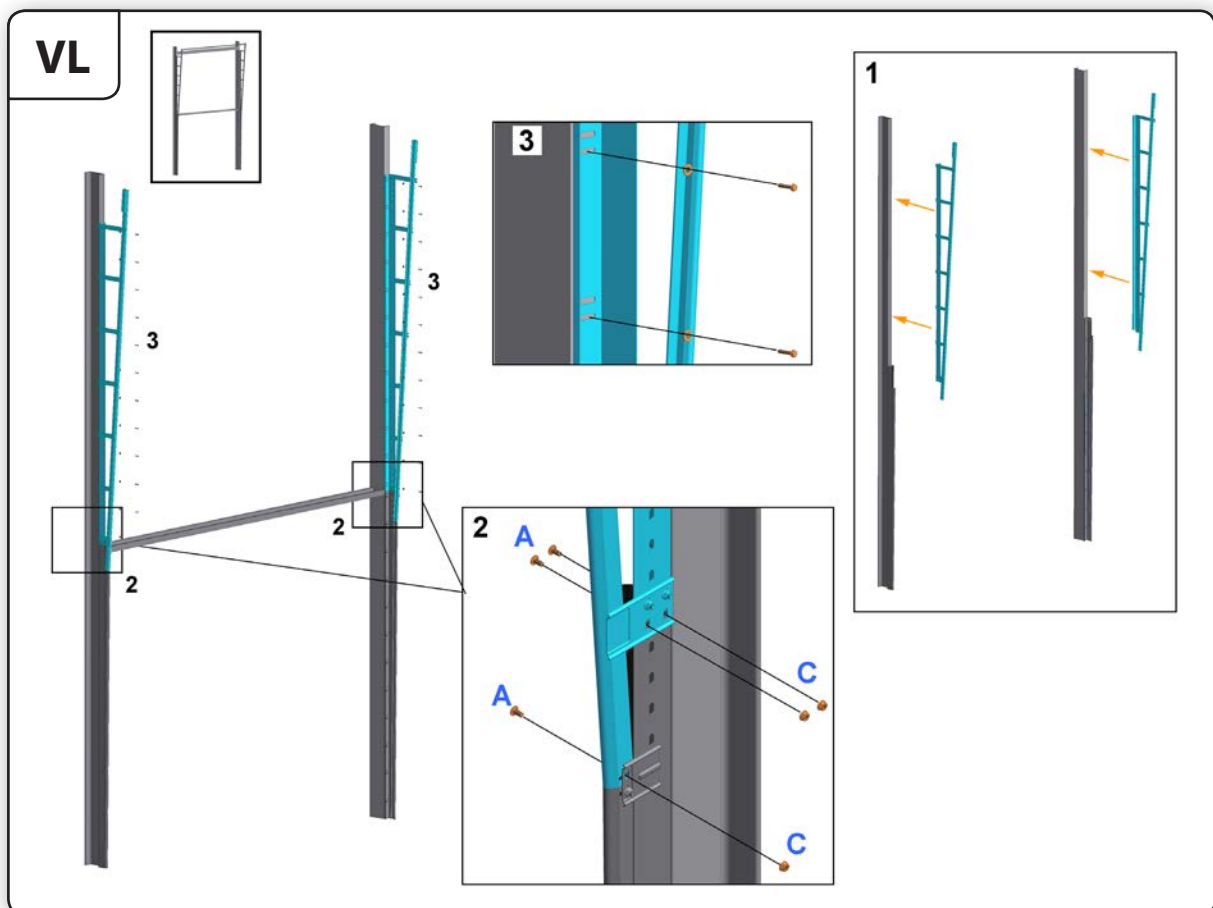
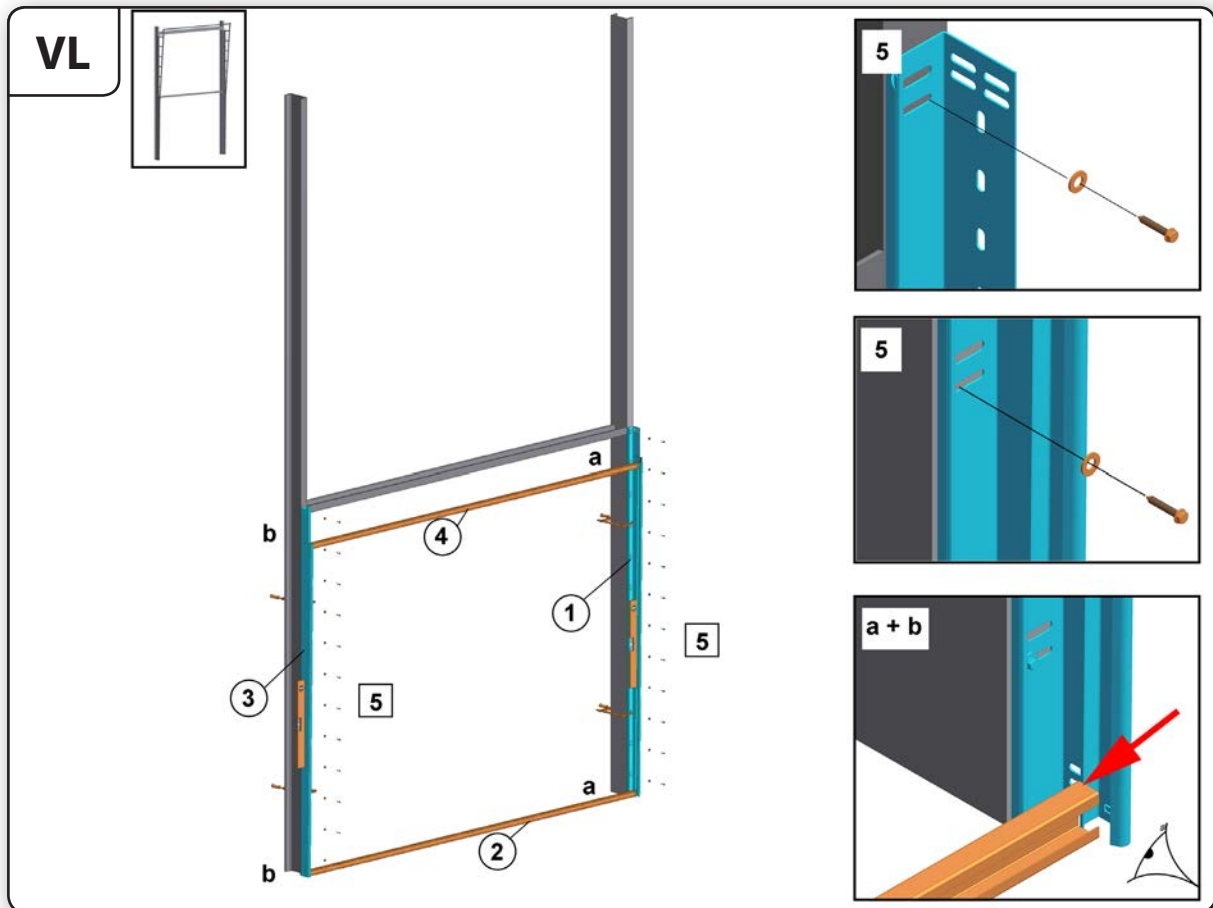

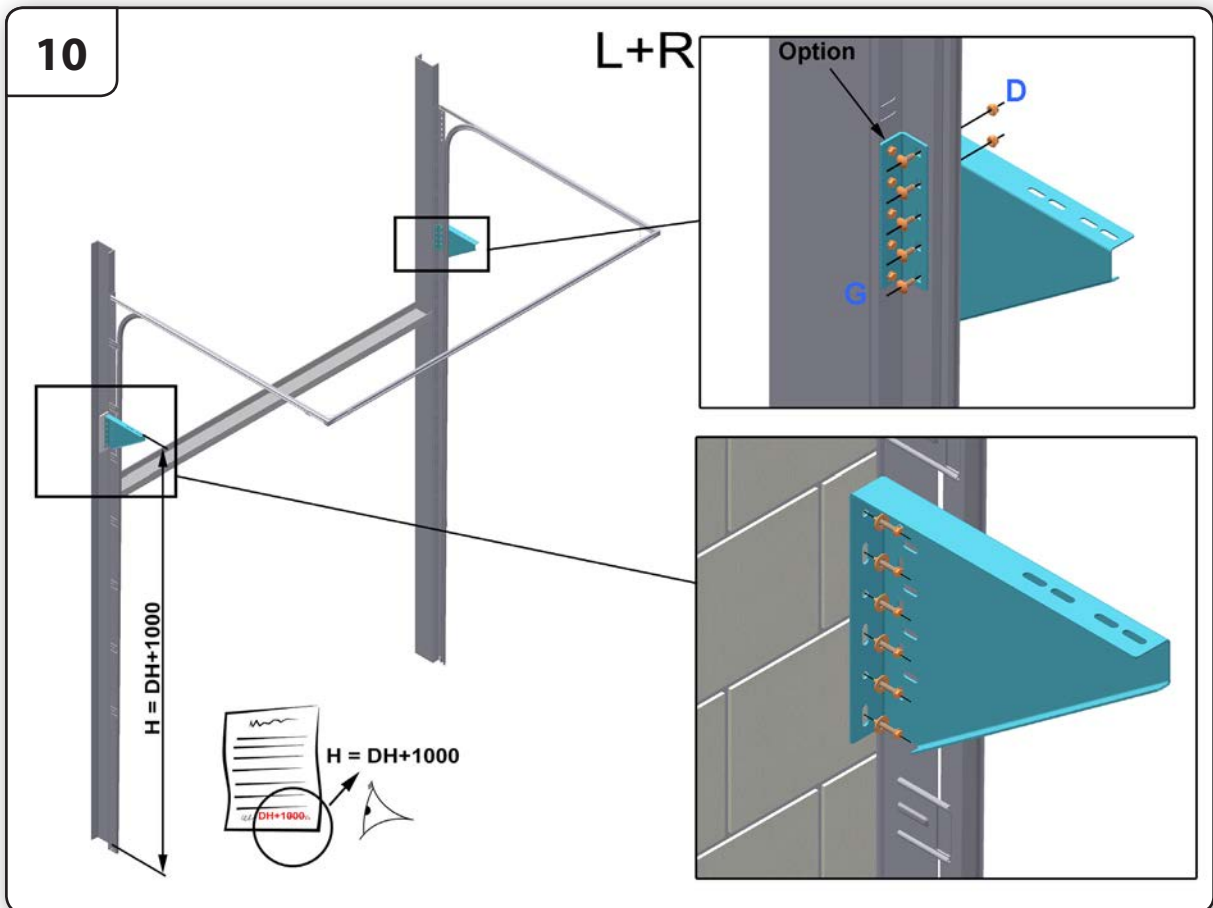
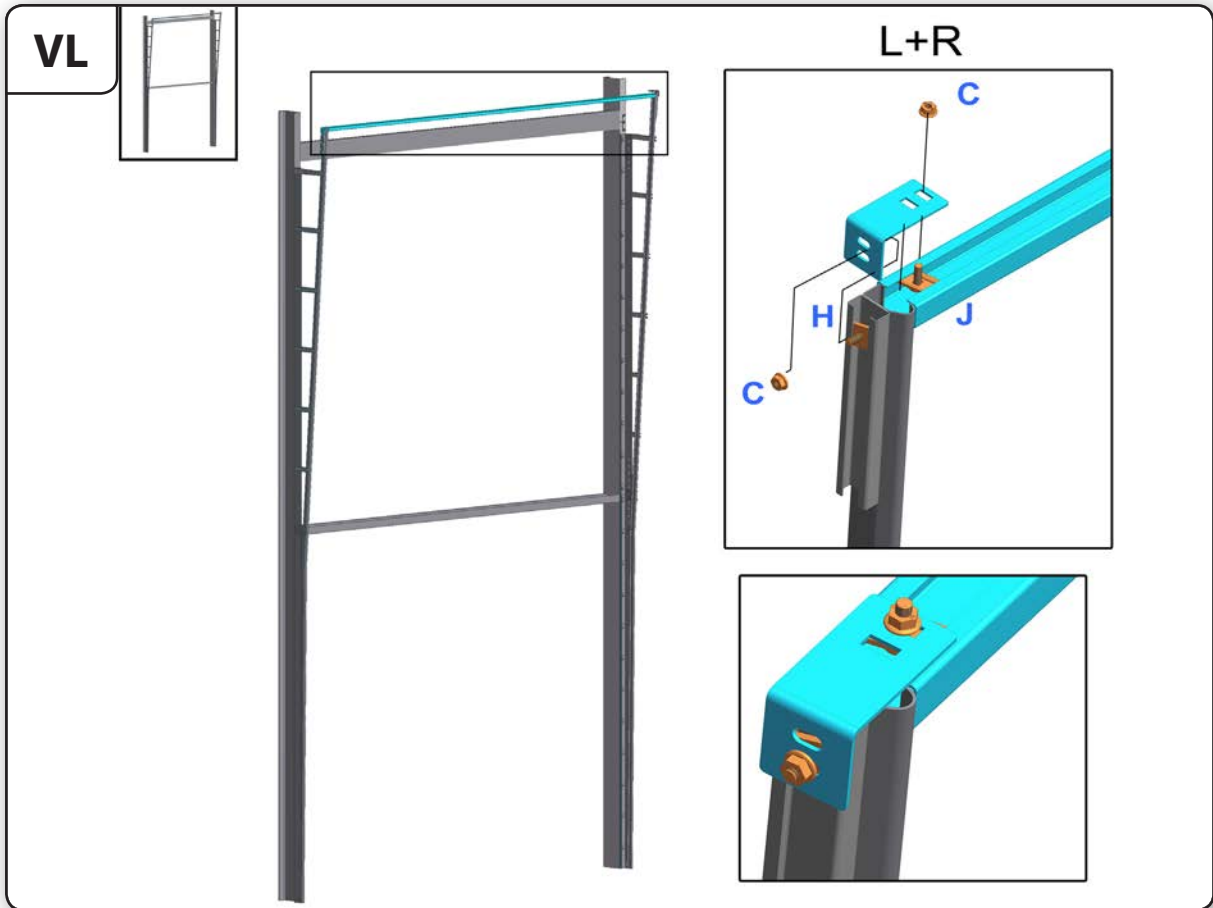

**11**

	HL		VL
110040	A	110090	B
110050	B	110100	A
110060	B	112020	B
110070	B	112021	A
110080	A		
112010	B		
112011	A		
112013	B		

**12**

**i** 25449

### 12.1

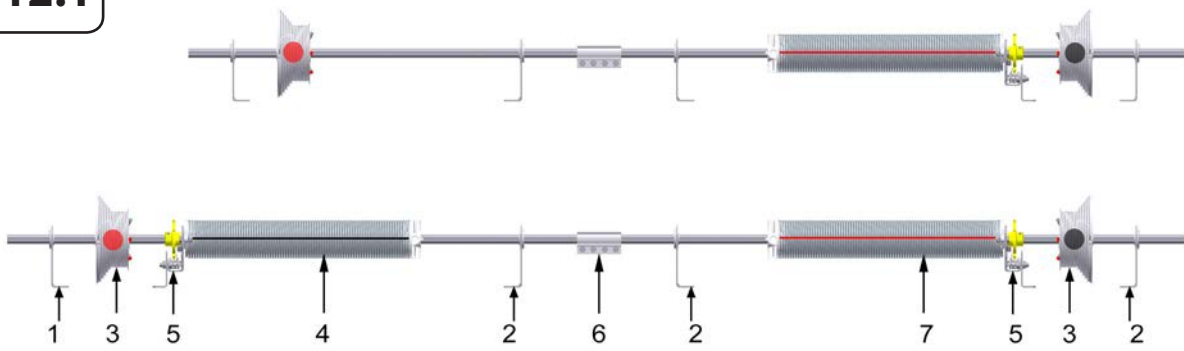

Offset [mm]	End bearing plate	Support bearing plate	Drum	Spring	Spring break device	Coupler	Spring
	1	2	3	4	5	6	7
86	130102	130102	Drums with 2 or 0,5 safety wrap (depends of drum), cable outside	Spring Left = Black or blue color code	25449 or 299540/41	25049 or 275001 or 25042	Spring Right = Red color code
111	130103	130103			25449 + 25448 or 299540/41 + 299560		
127	130104	130104			25449 + 25448 or 299540/41 + 299560		
152	130105	130105			25449 + 25448 or 299540/41 + 299560		

### 12.2

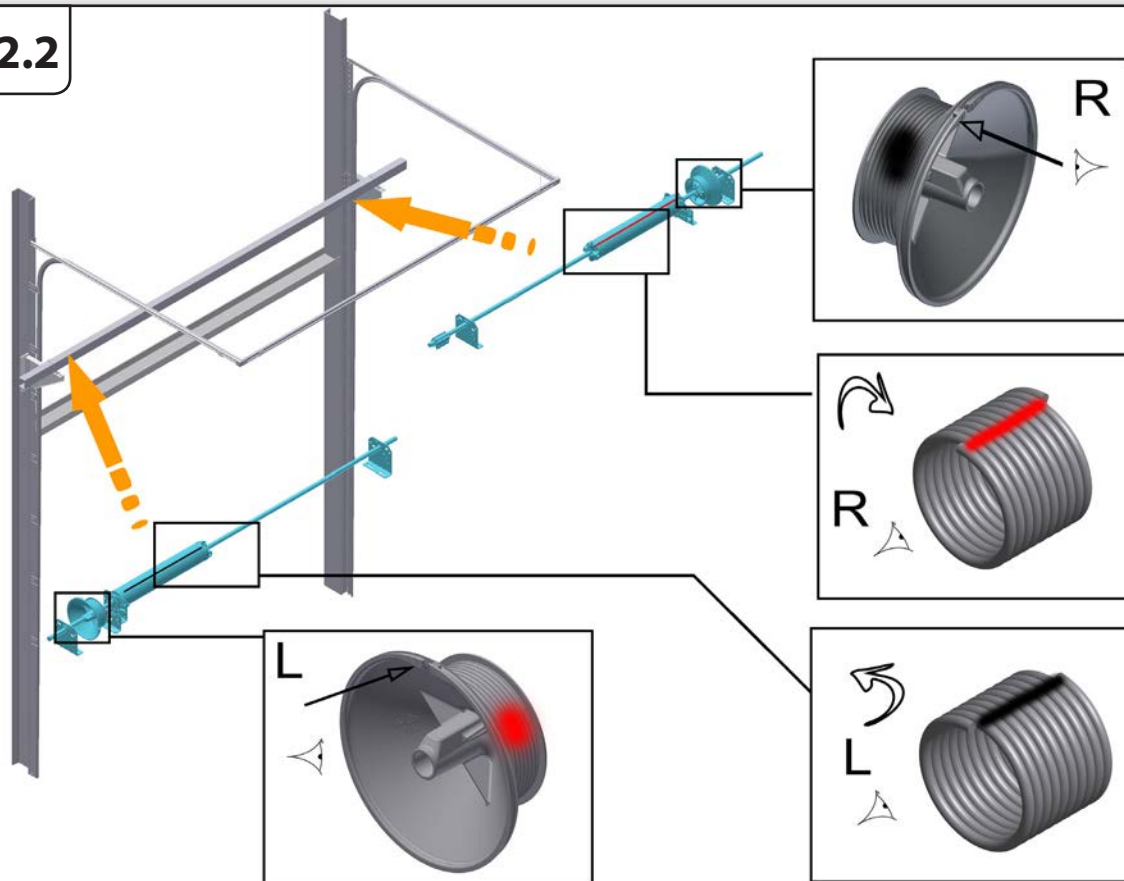

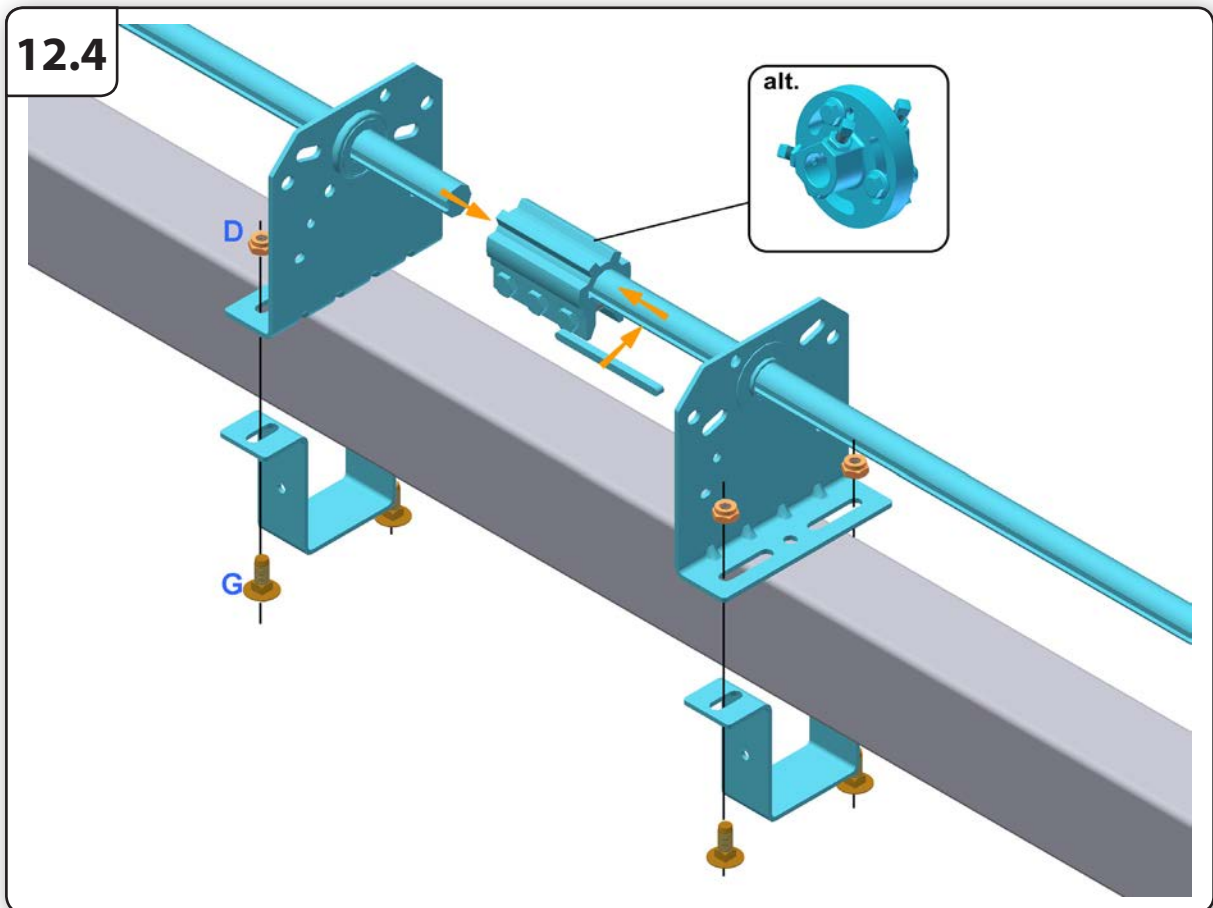
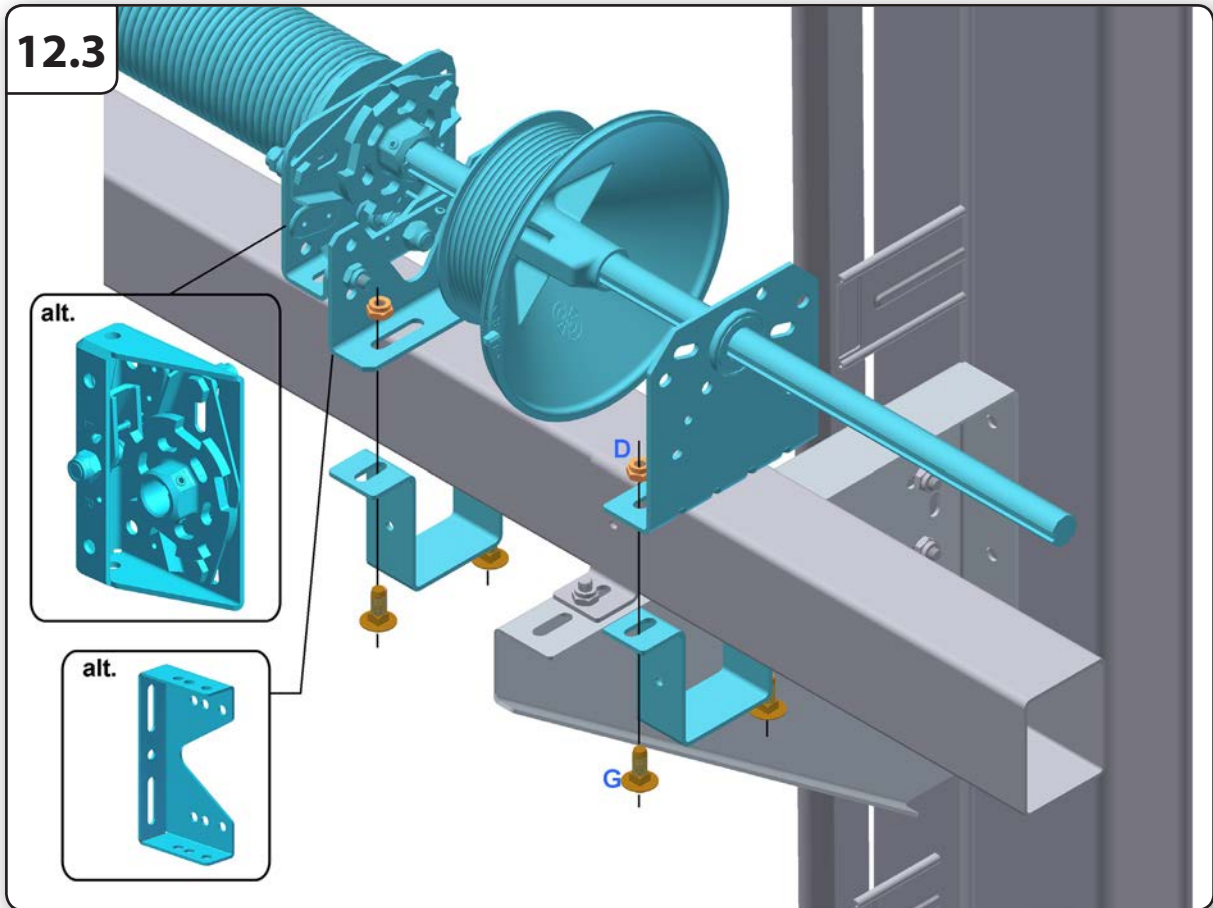

12.5

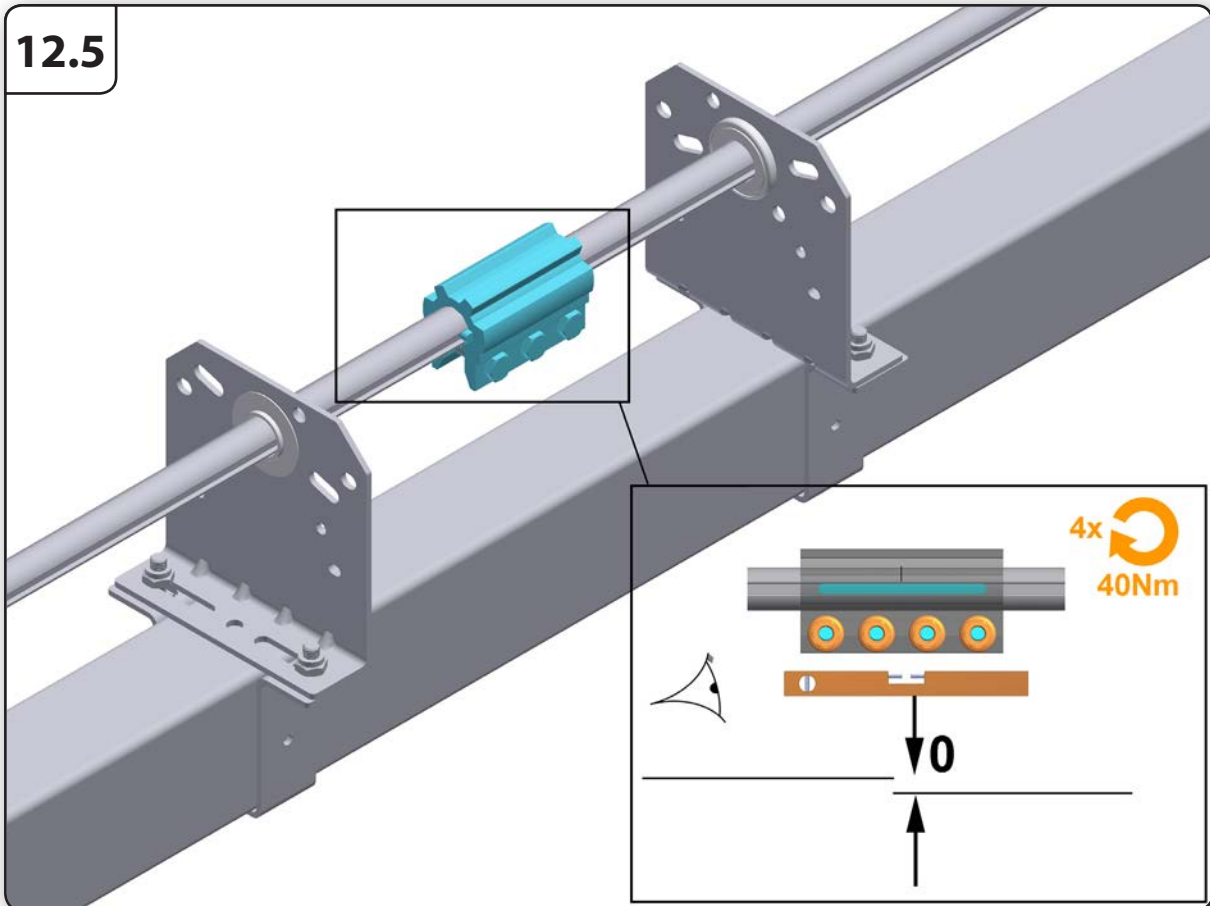

13

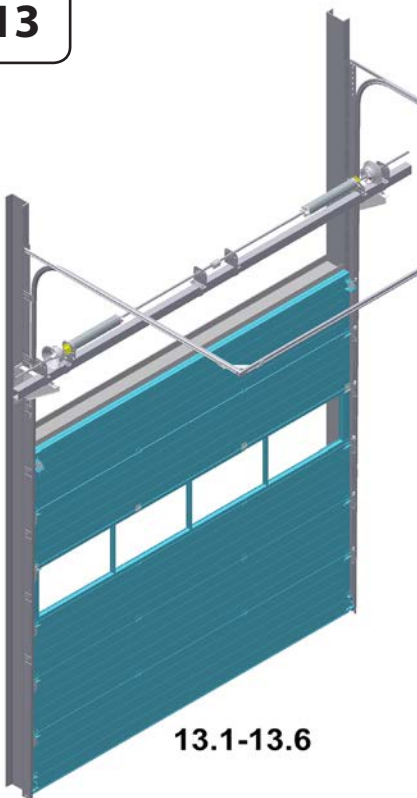

13.1-13.6



- Panel assembly
- Paneele montage
- Panneaux montage
- Panel montanje
- Pannelli montaggio
- Montáž na Panel
- Montaž Panelu
- Paneel montage

25450 / 25454



Max. 660 kg  
(system)

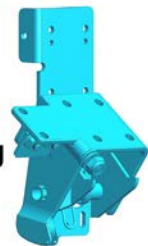

25032



Max. 600 kg  
(system)



25455



Max. 450 kg  
(system)



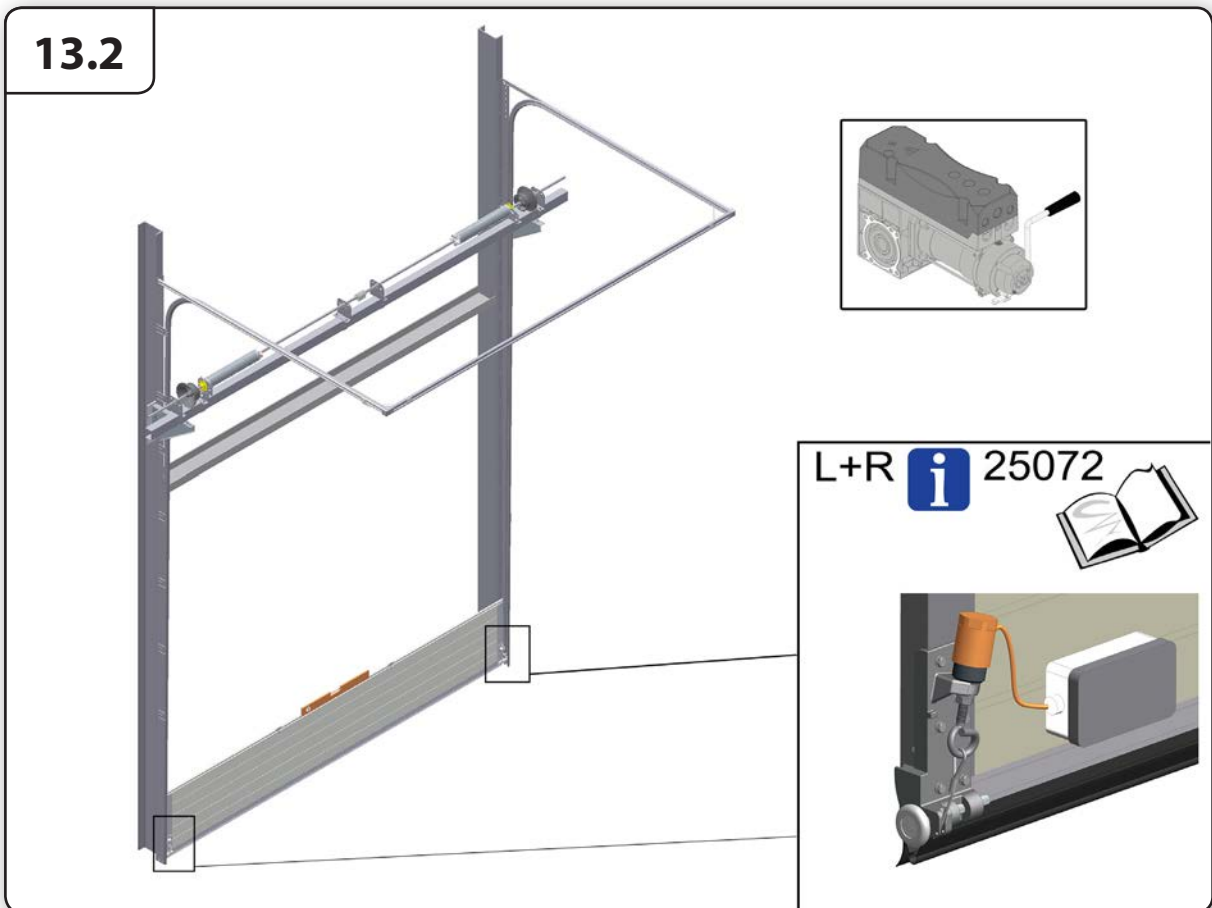
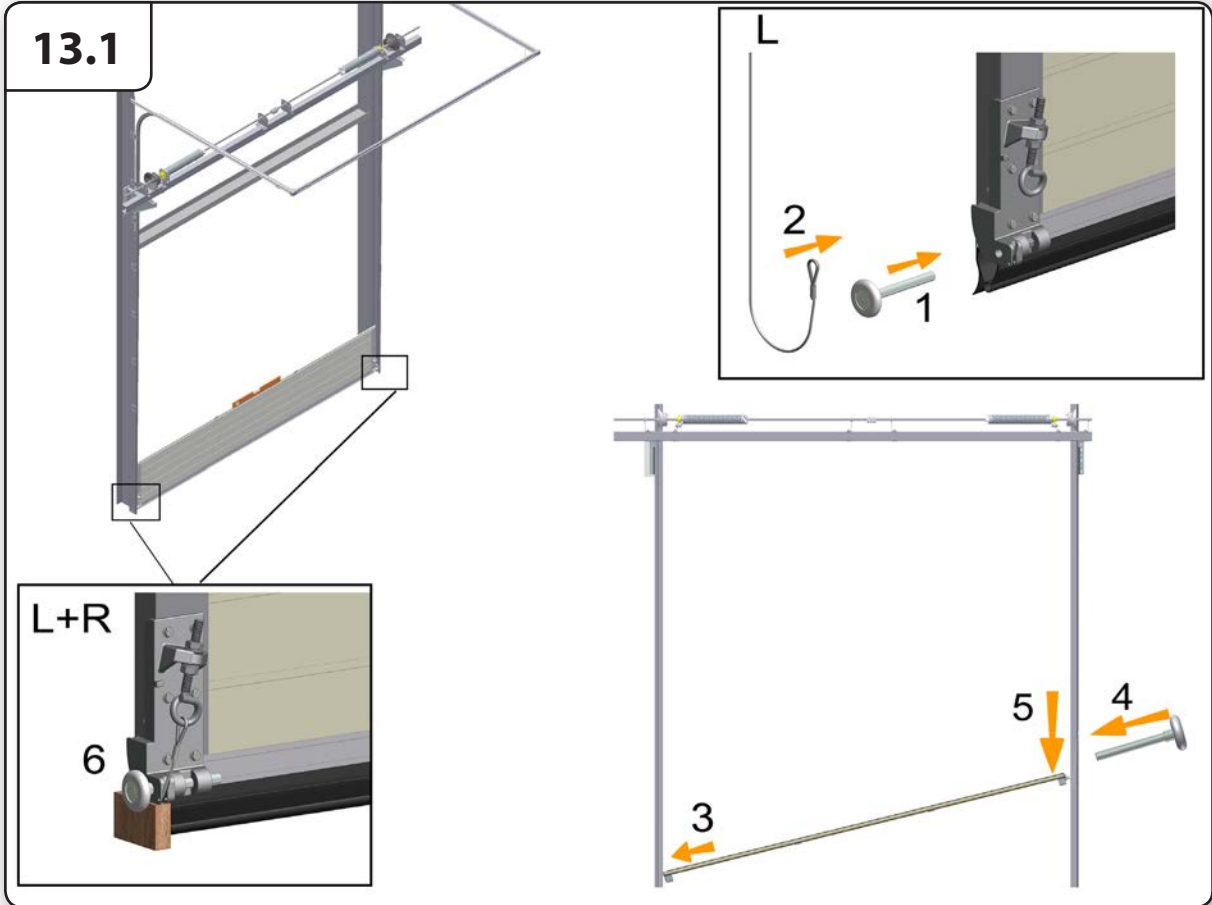

**13.3**

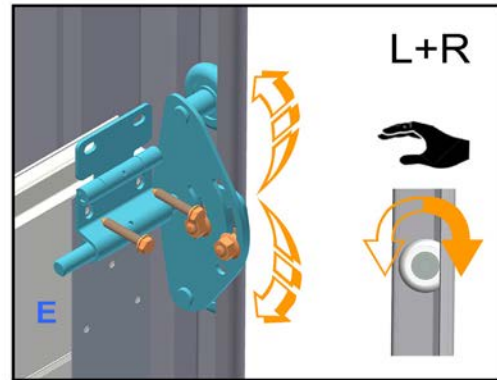
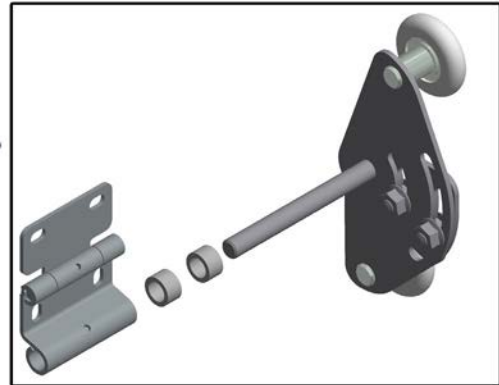
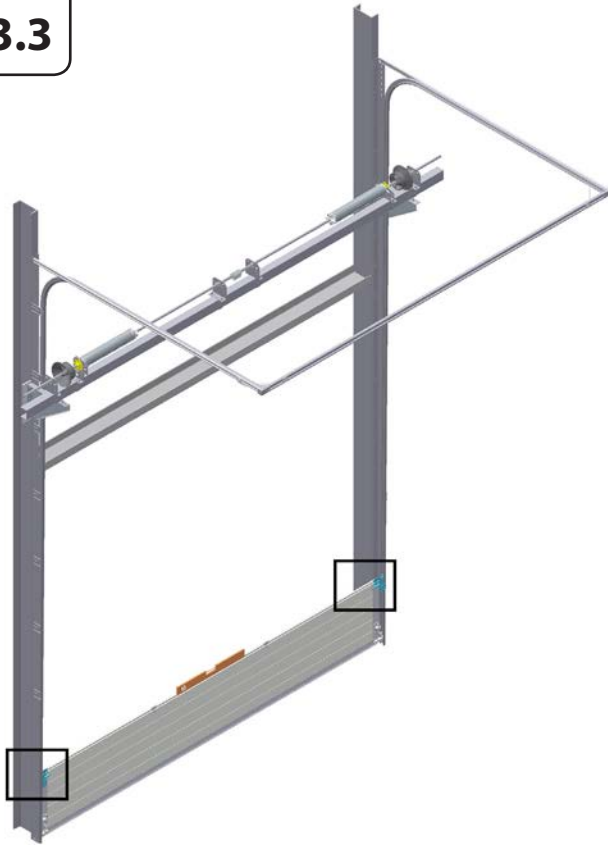

**13.4**

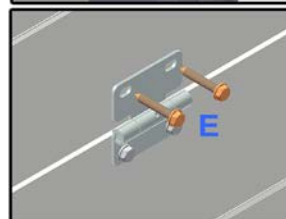
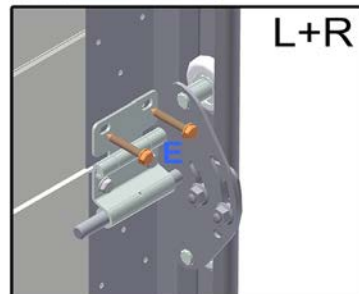
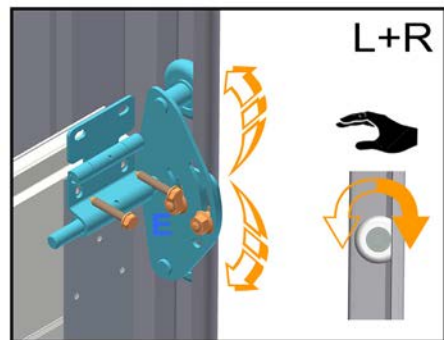

**13.5**

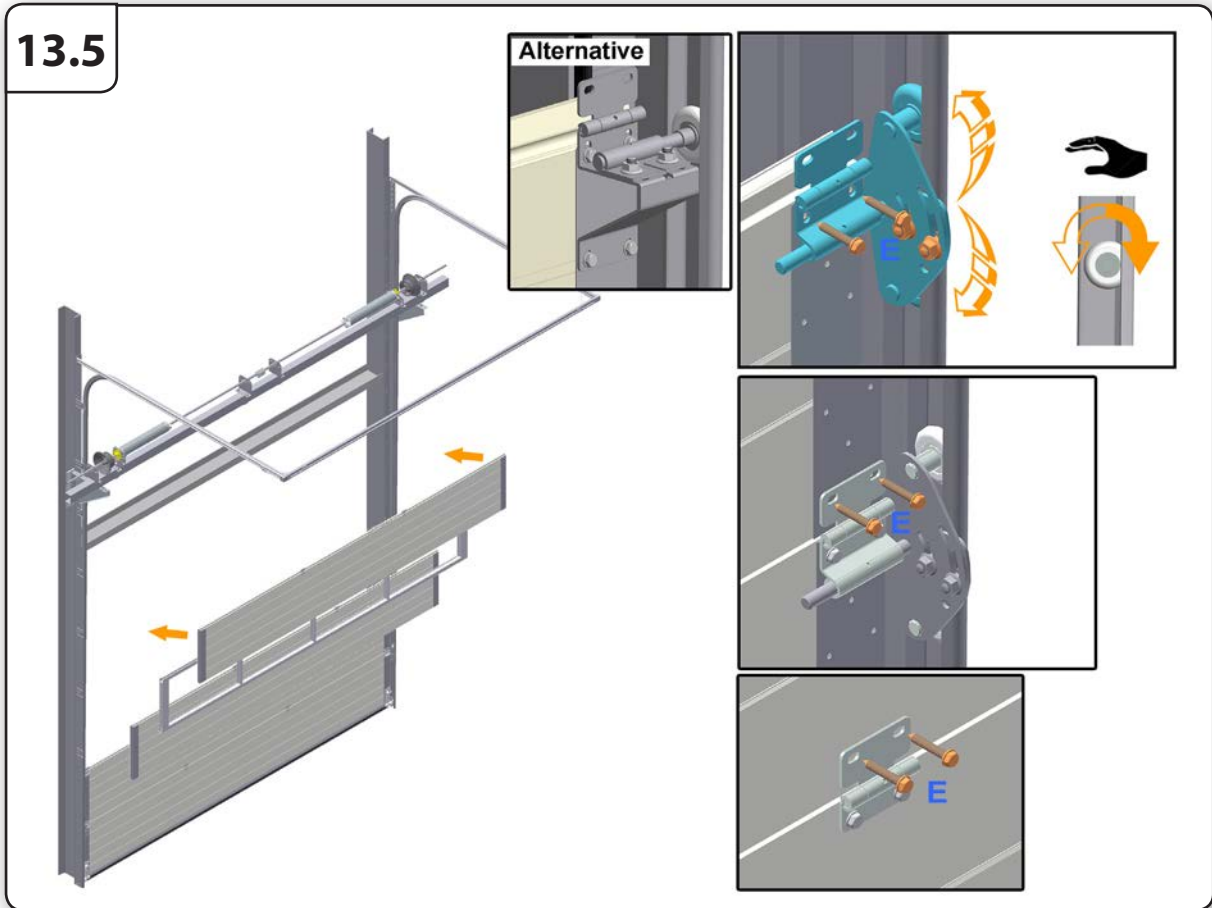

**13.6**

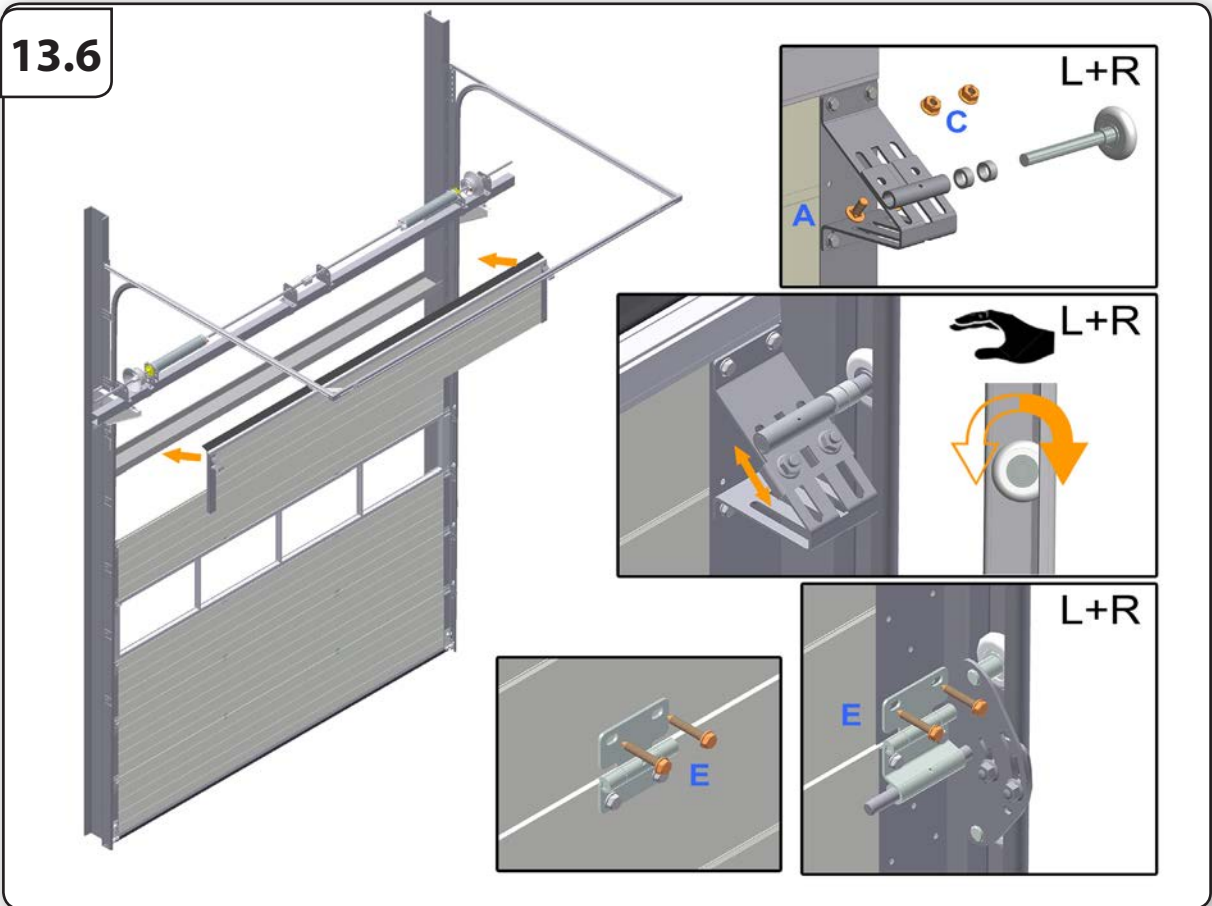

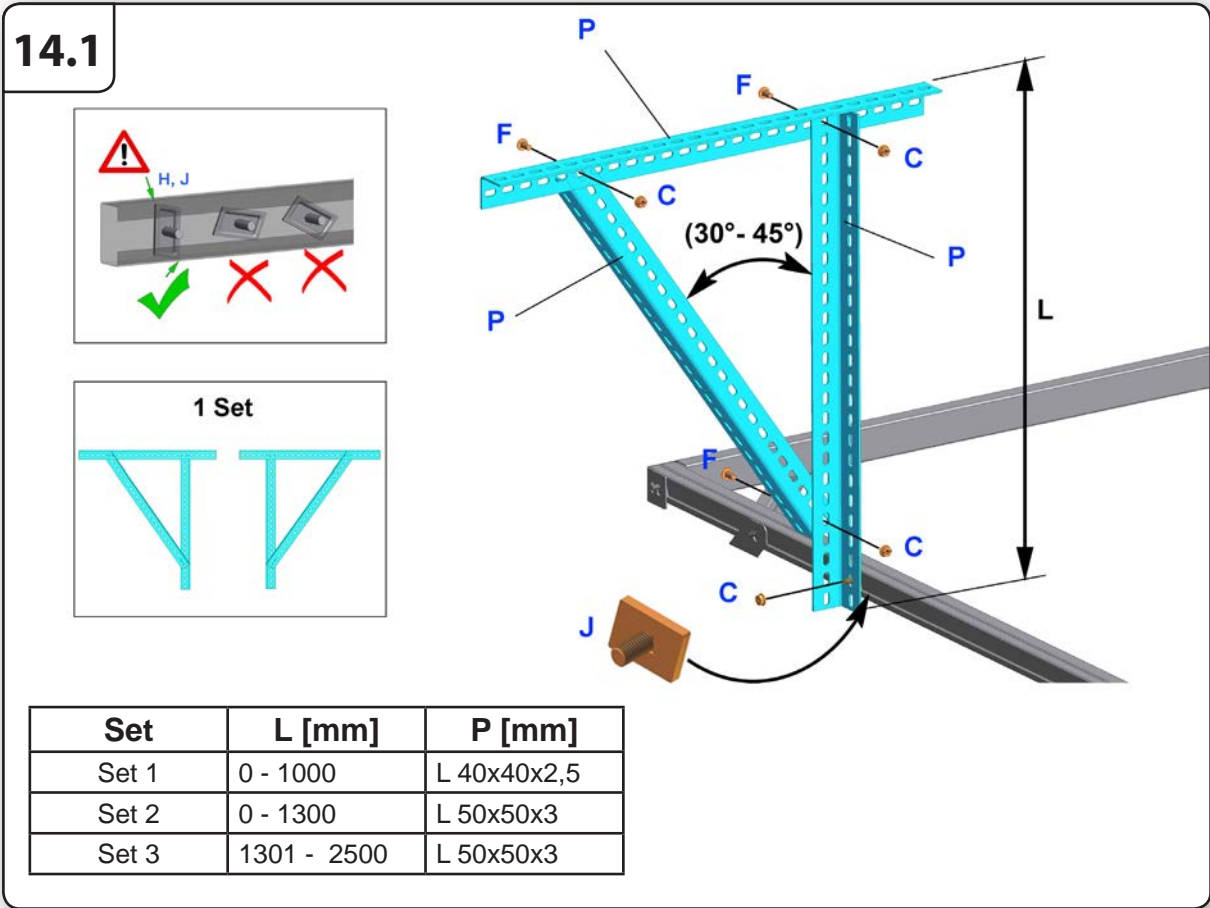
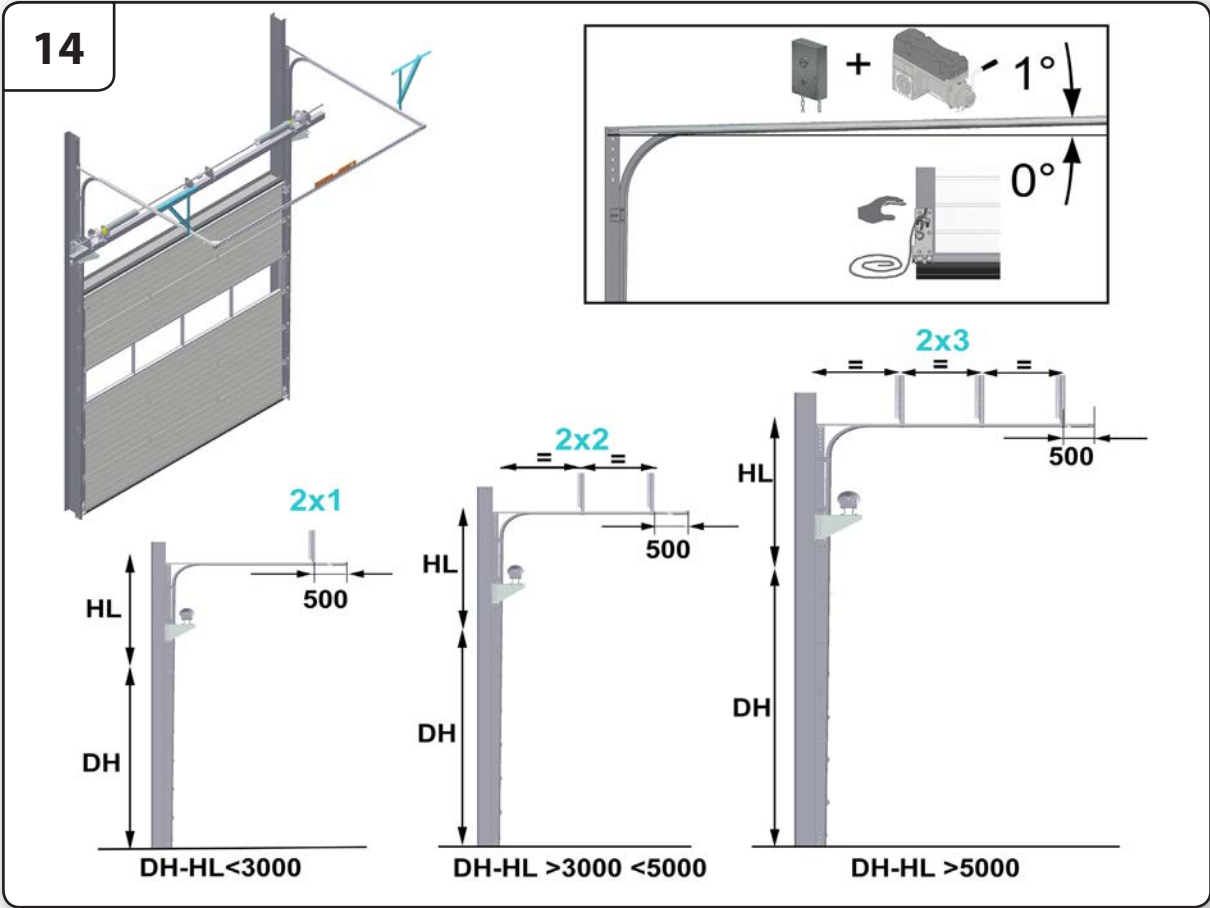

15

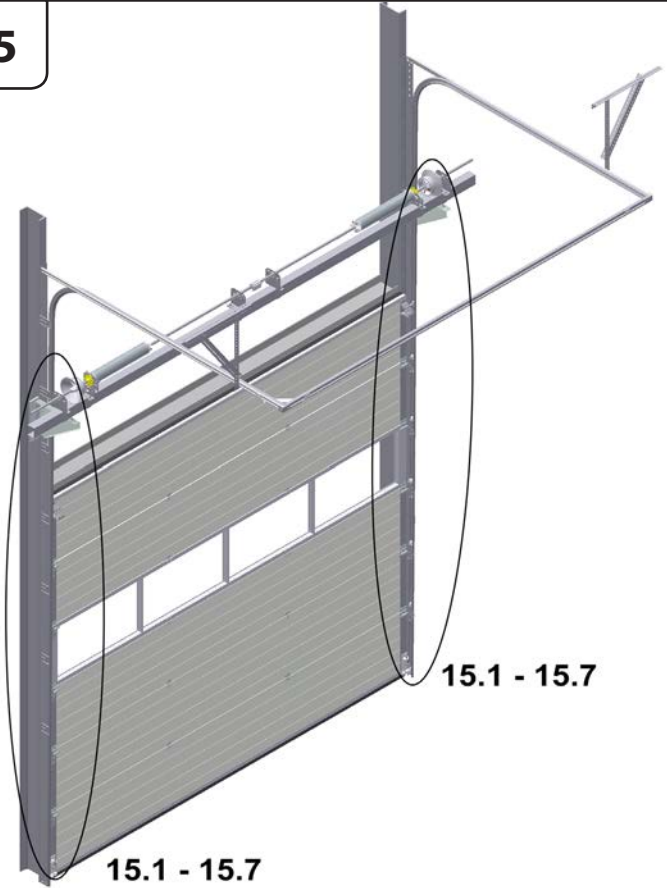

**15.1 - 15.7**

**15.1 - 15.7**



3 mm : max. 166 kg  
 4 mm : max. 295 kg  
 5 mm : max. 463 kg  
 6 mm : max. 660 kg

15.1

L+R

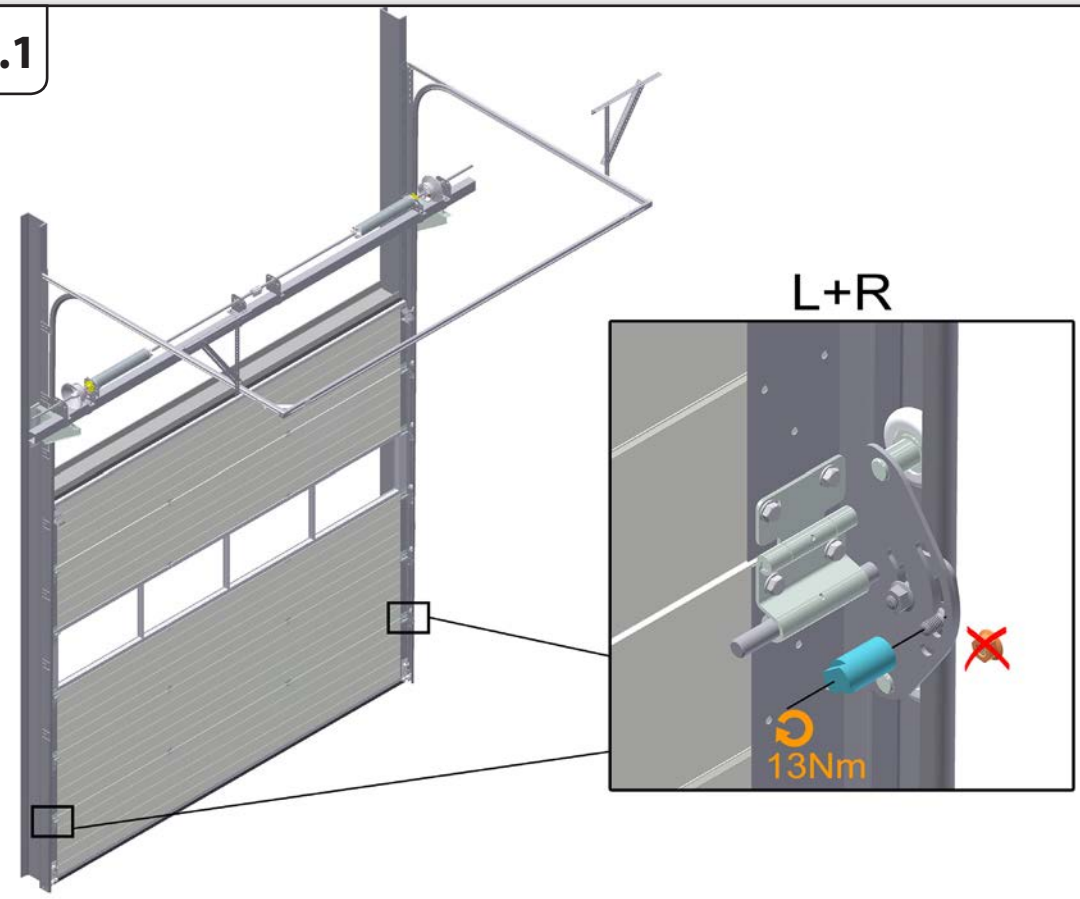

13Nm

**15.2**

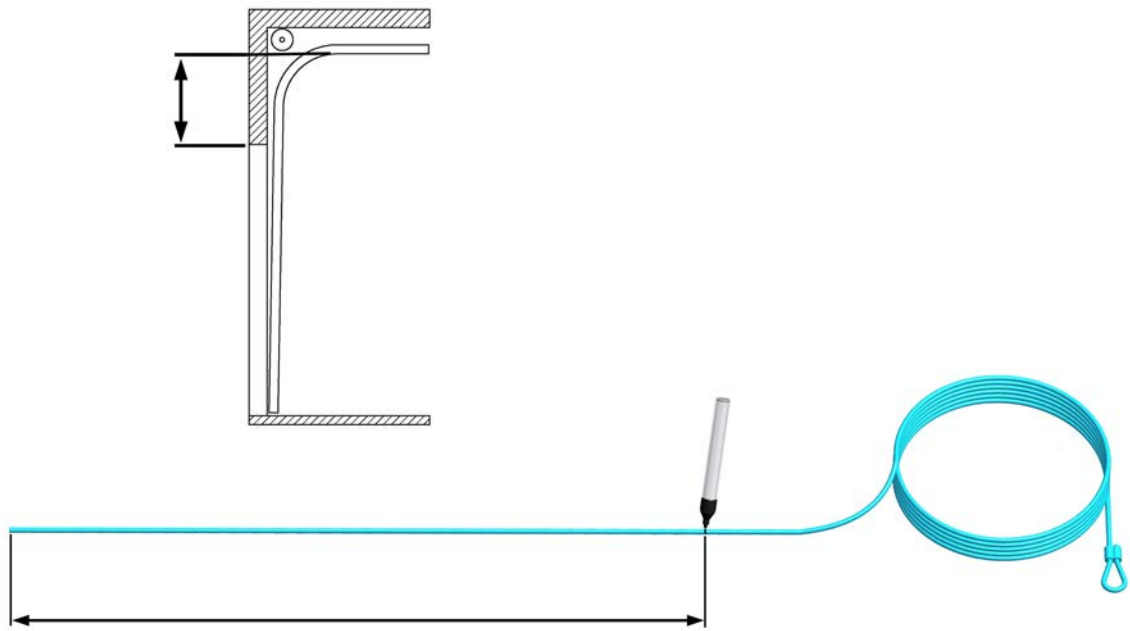

**15.3**

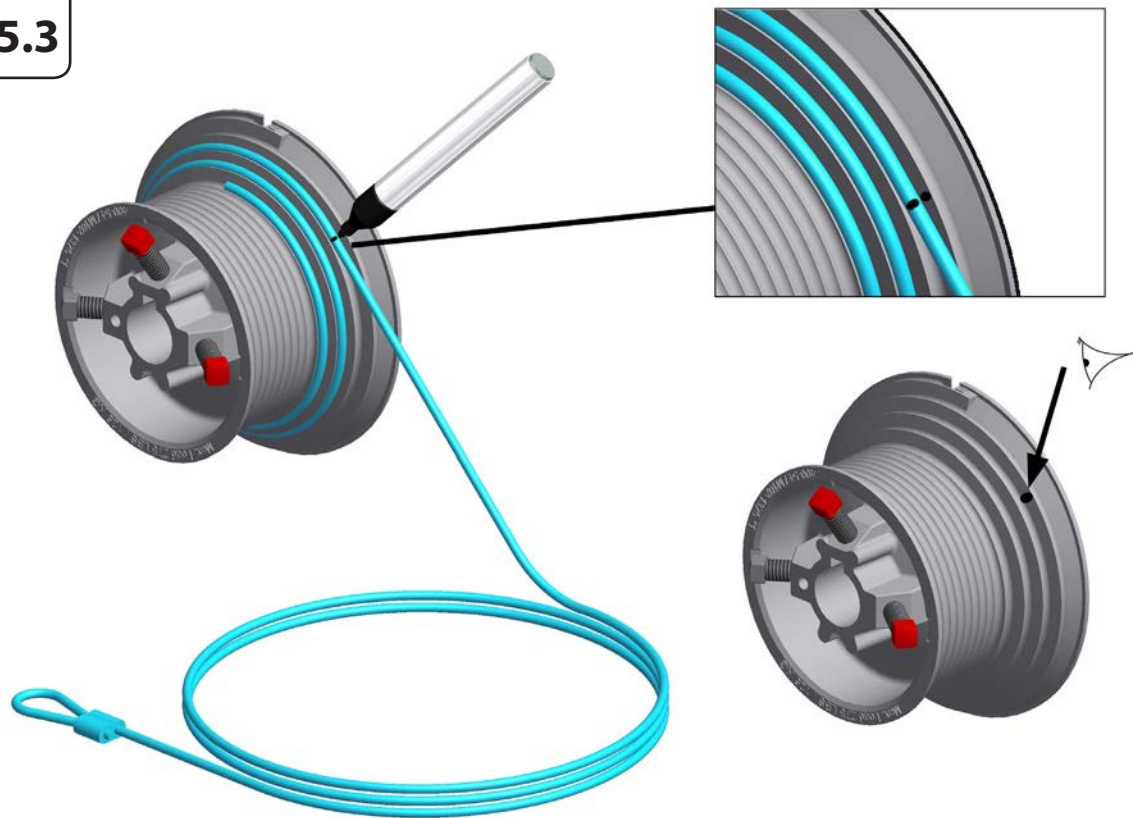

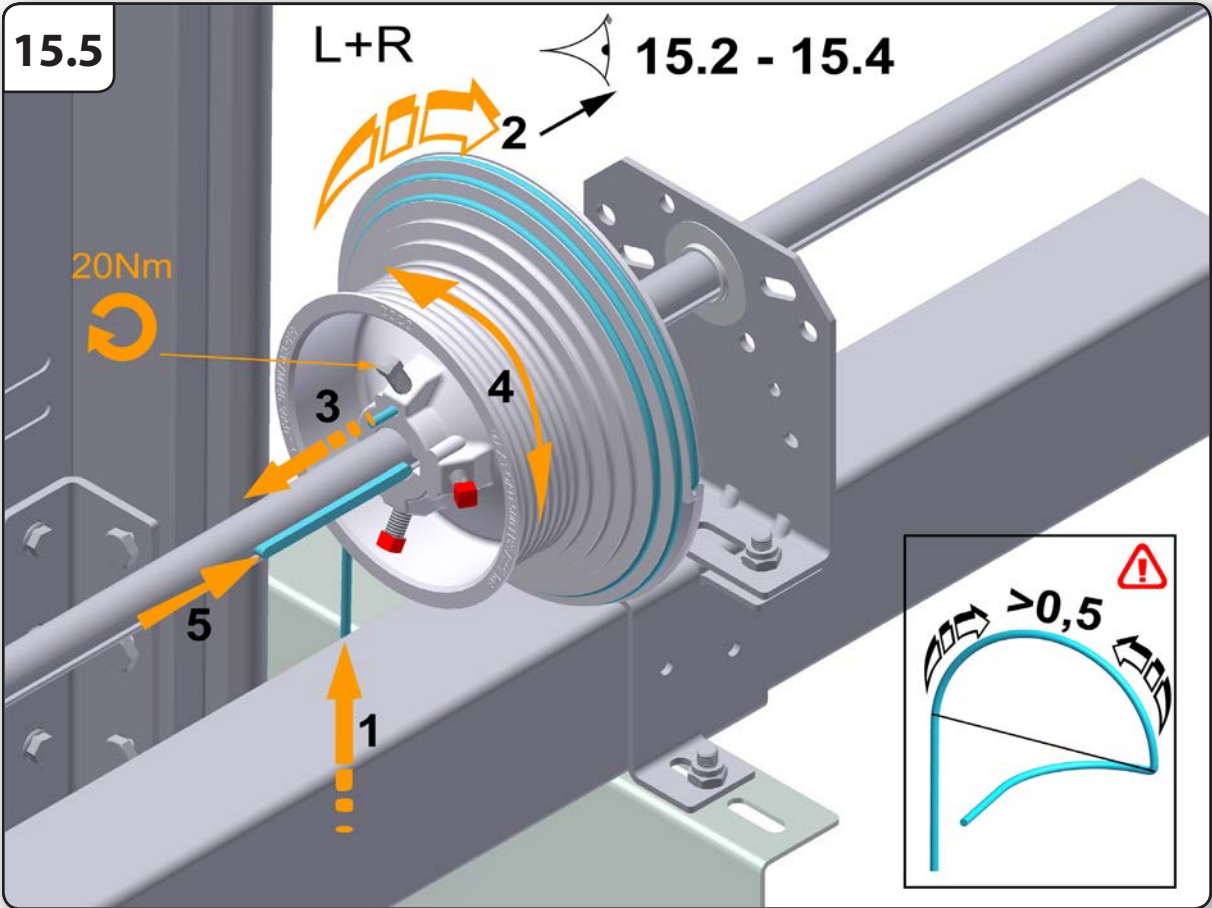
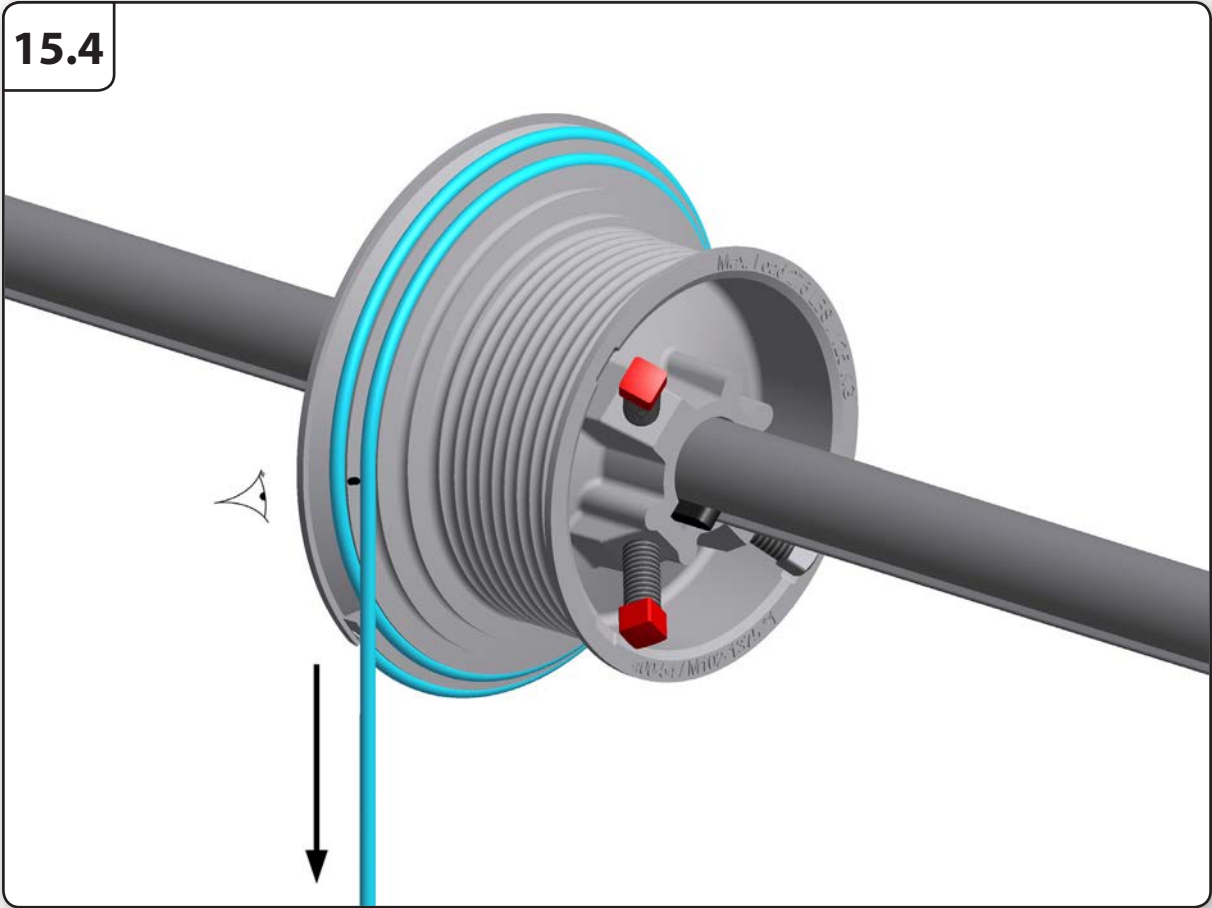

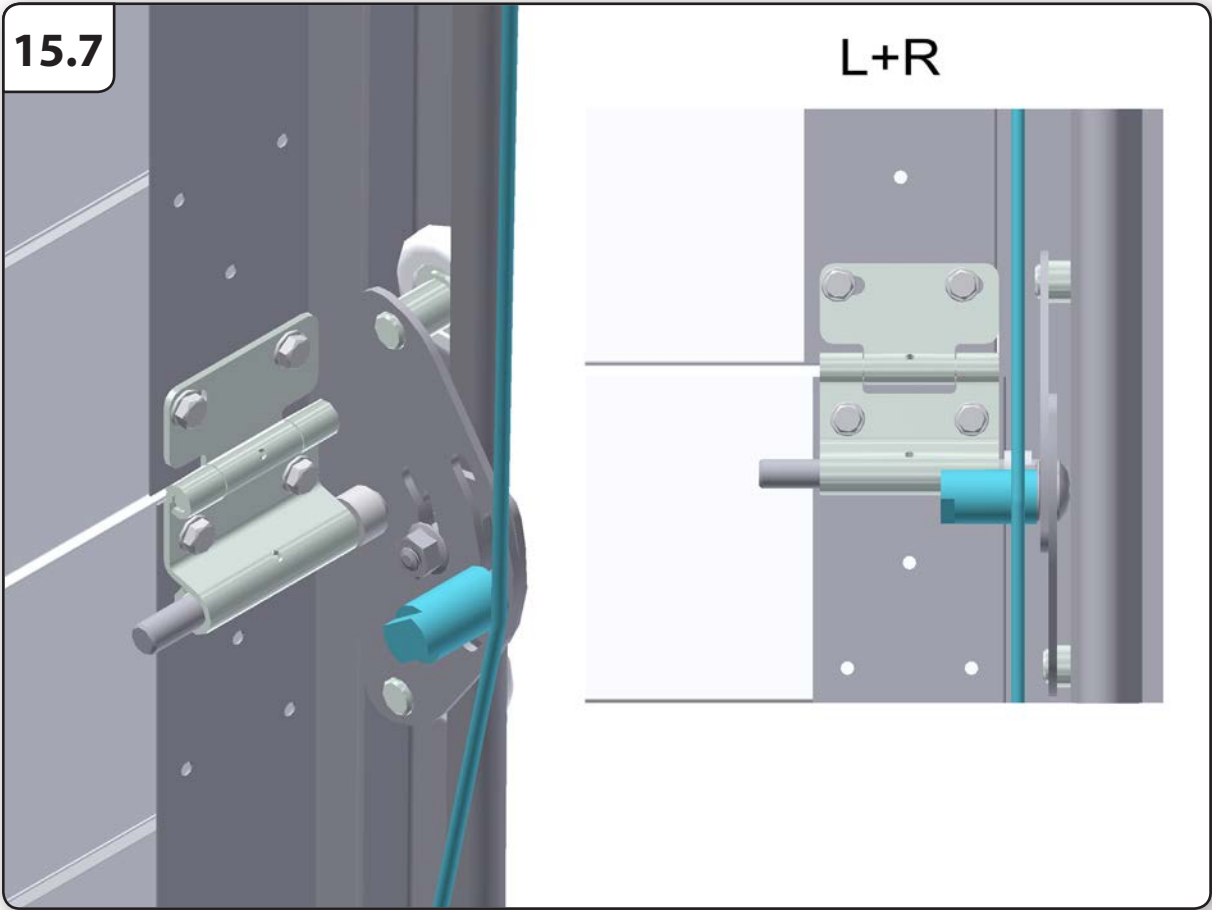
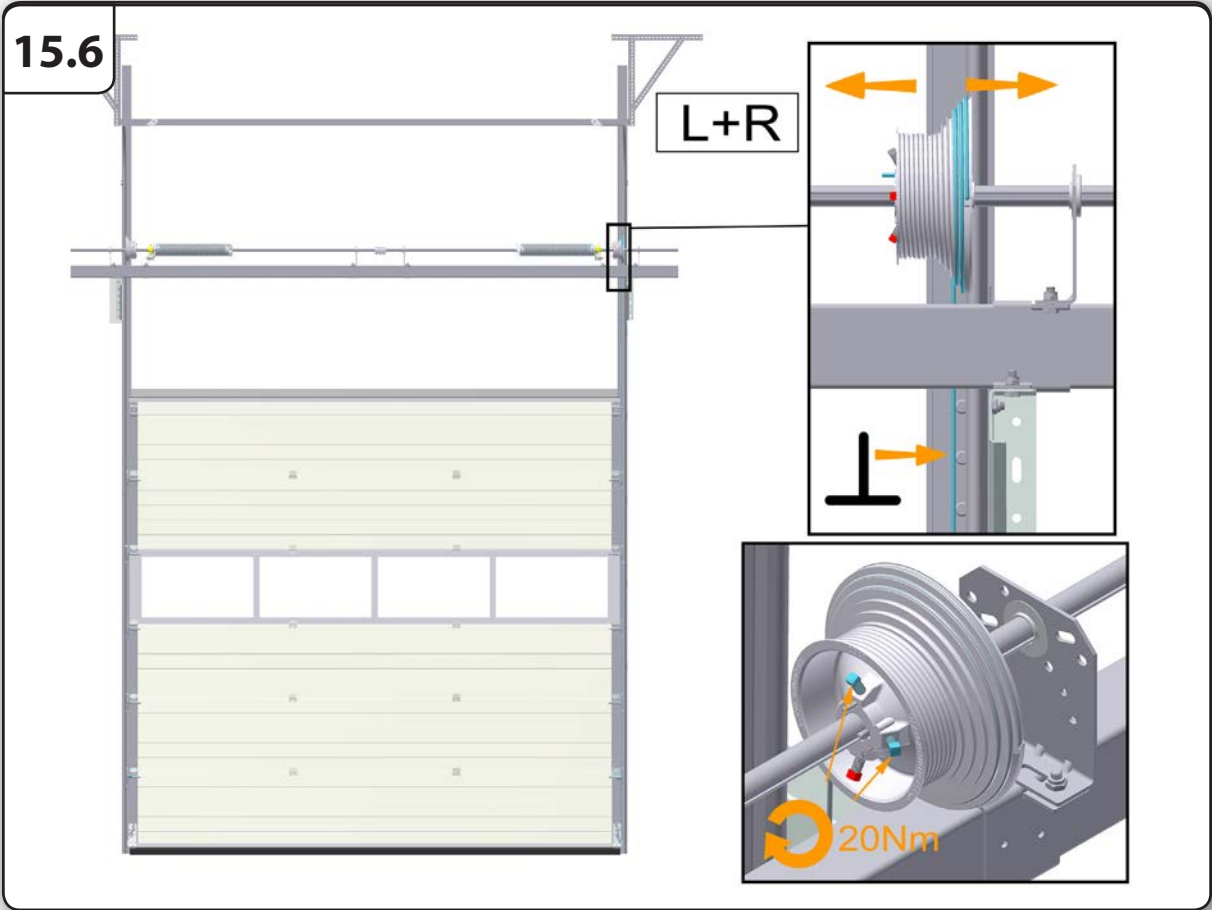

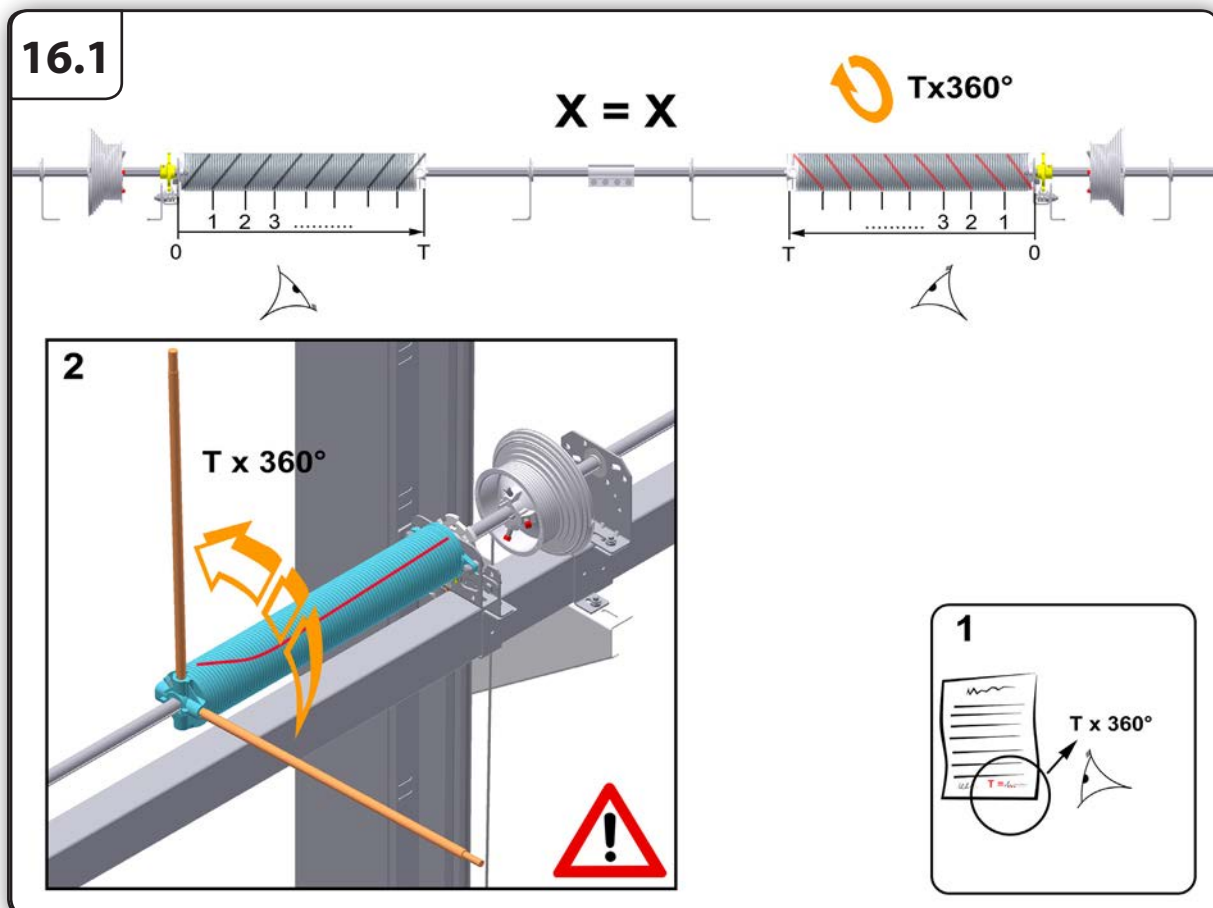
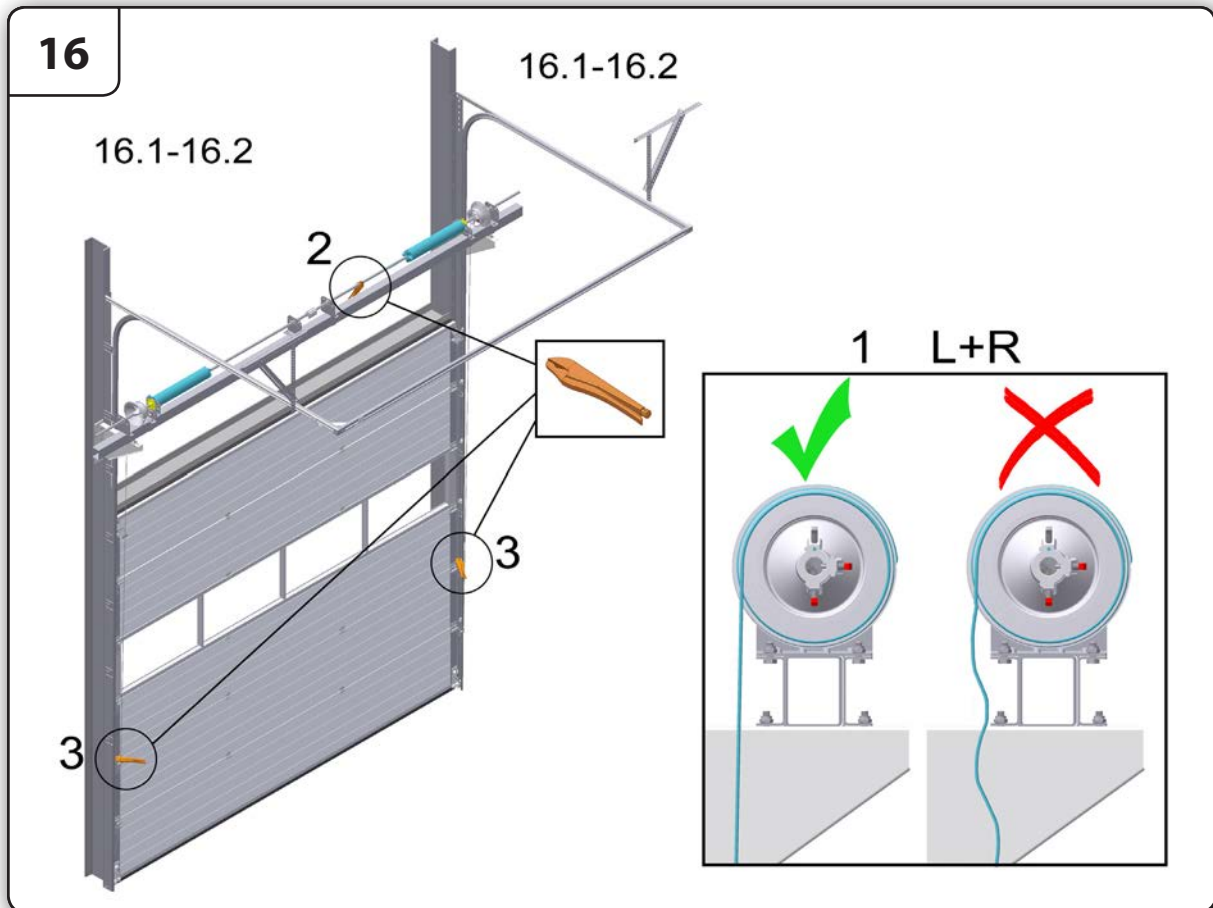

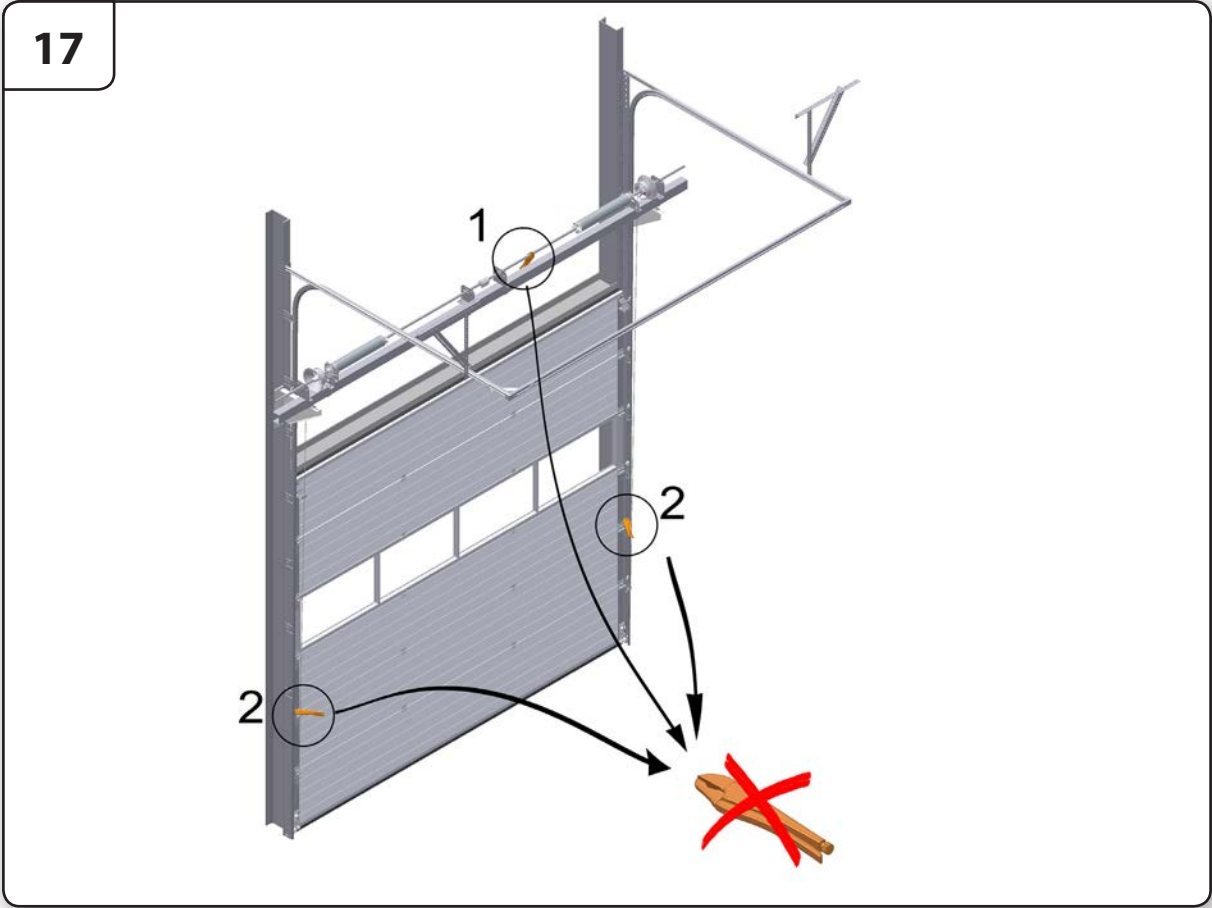
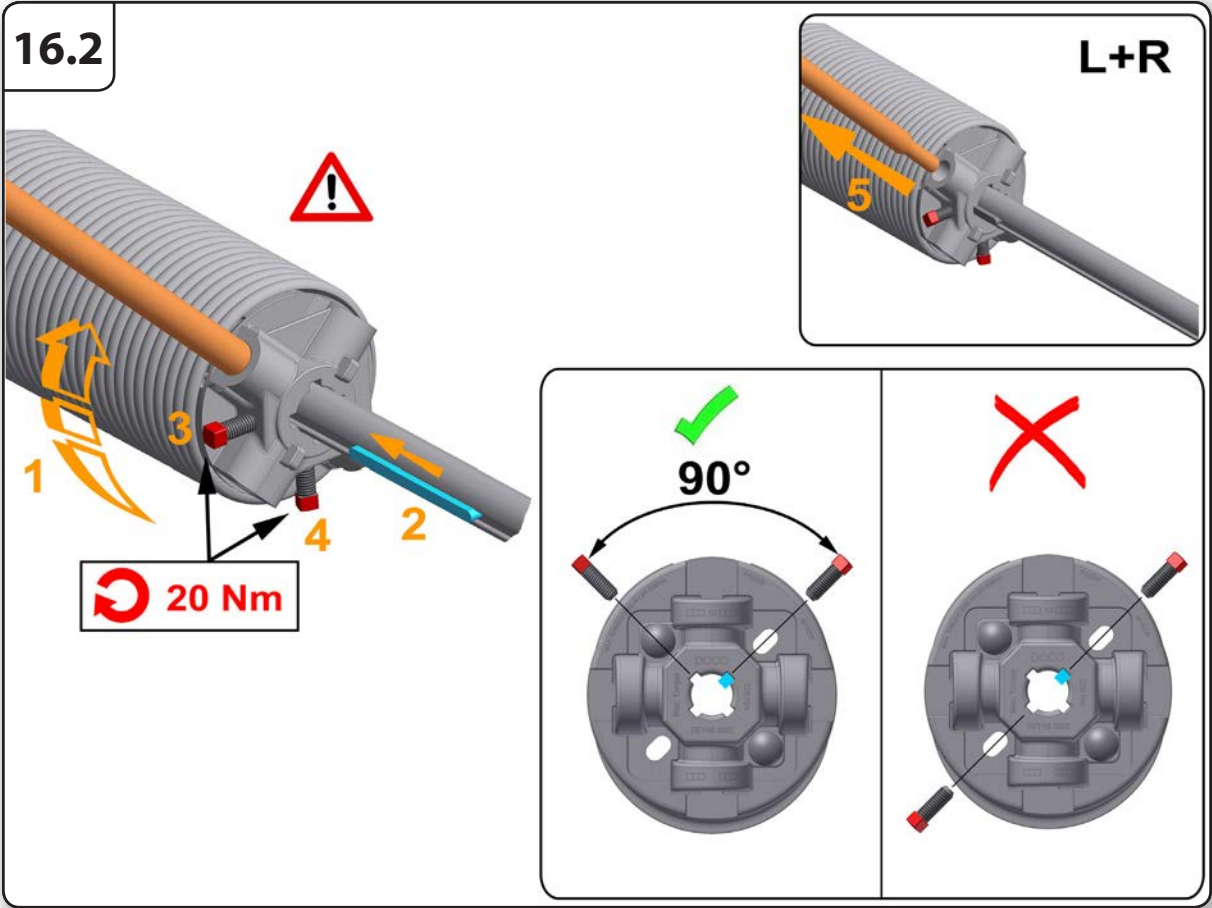

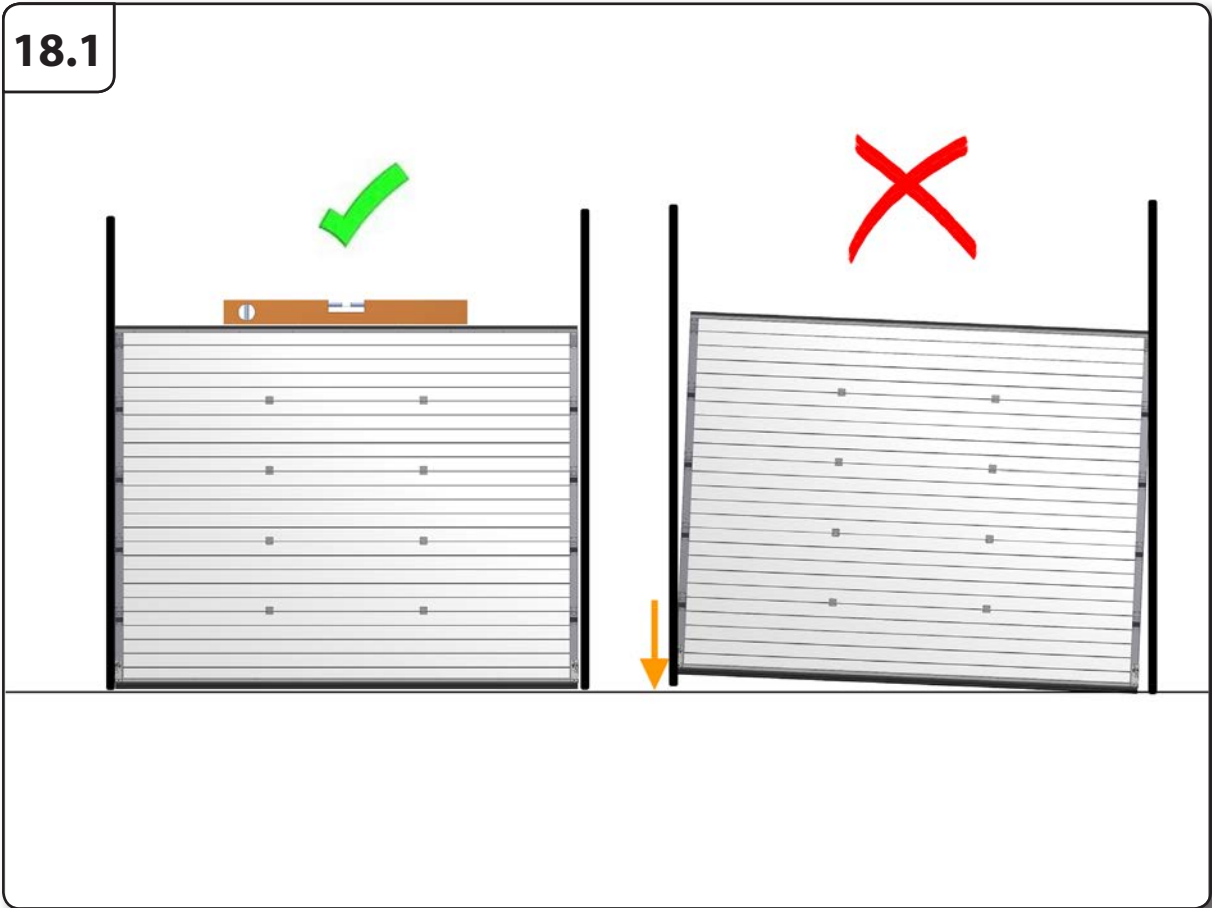
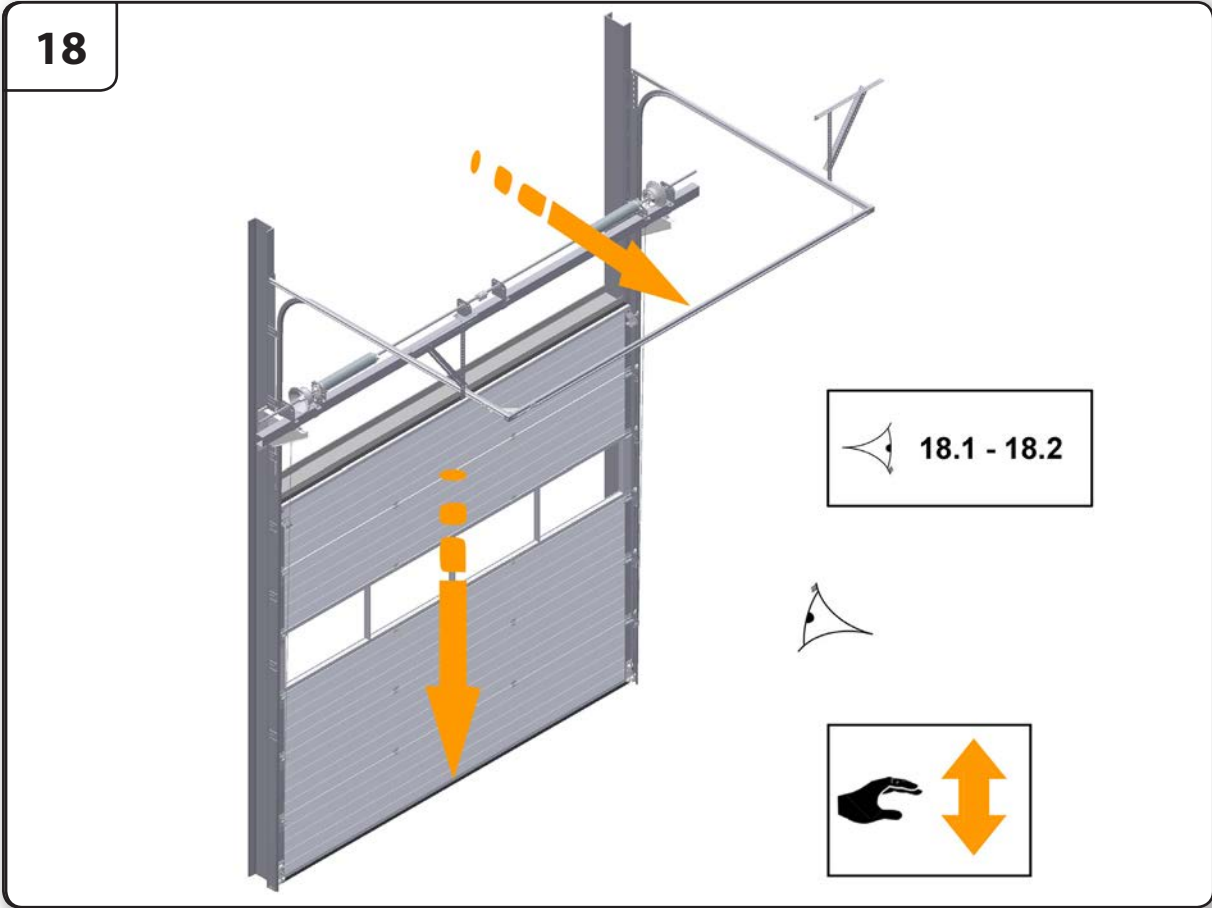

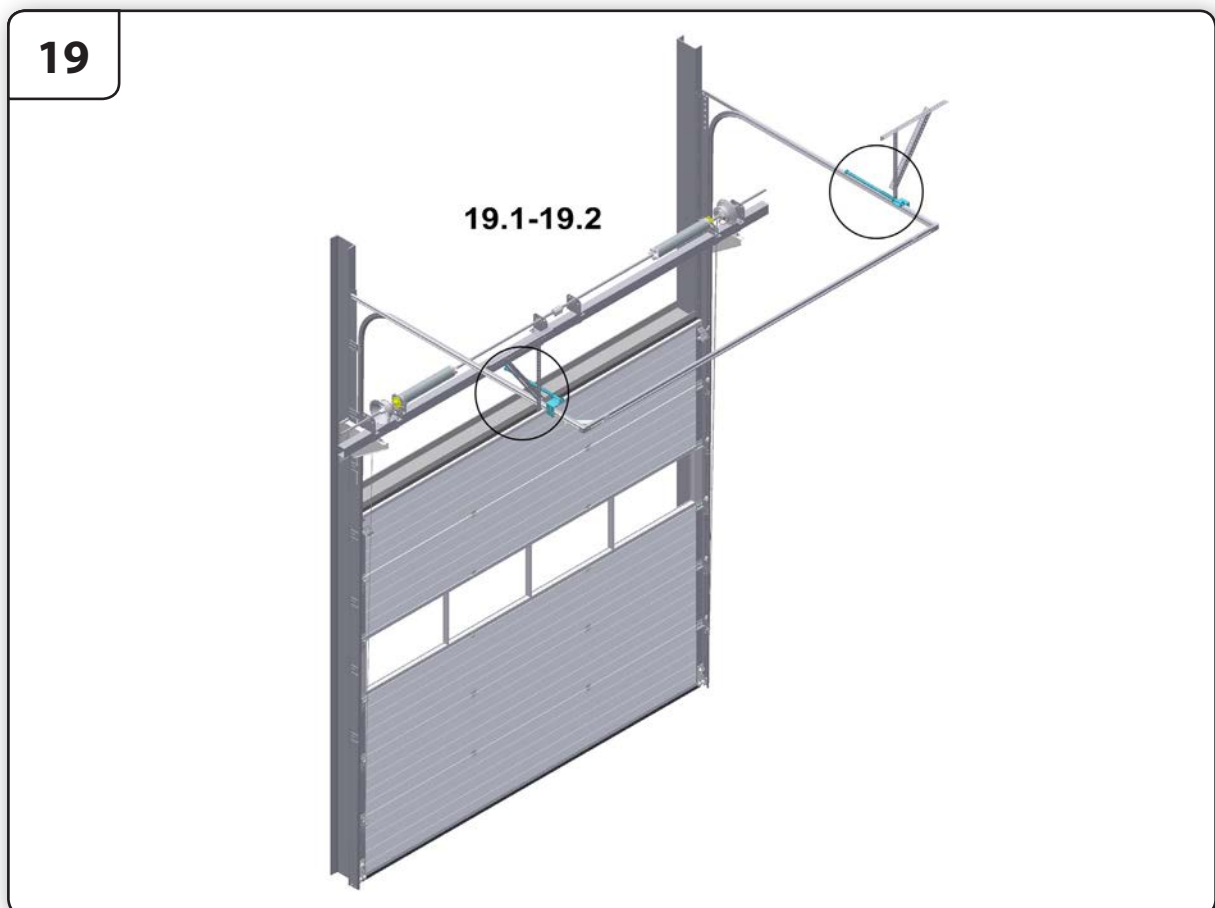
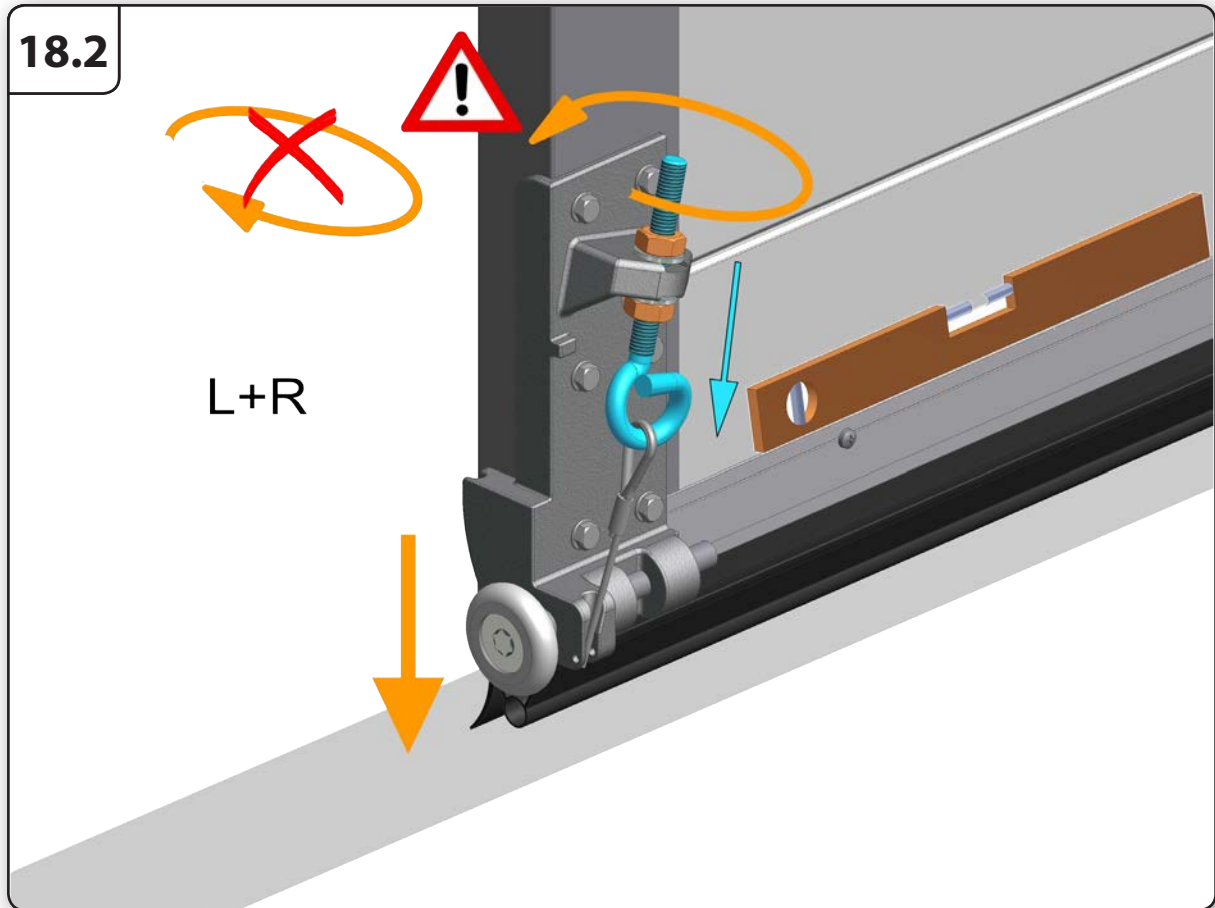

**19.1**

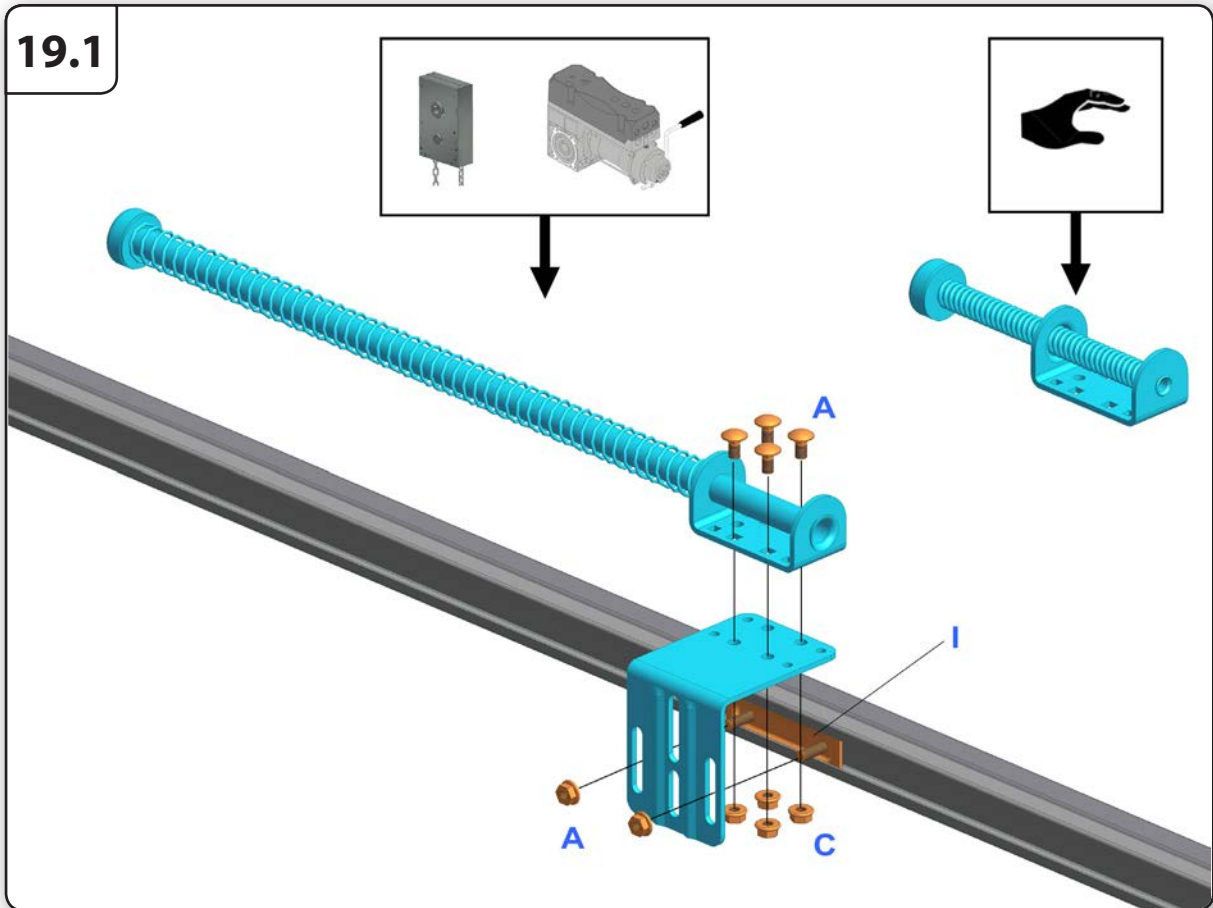

**19.2**

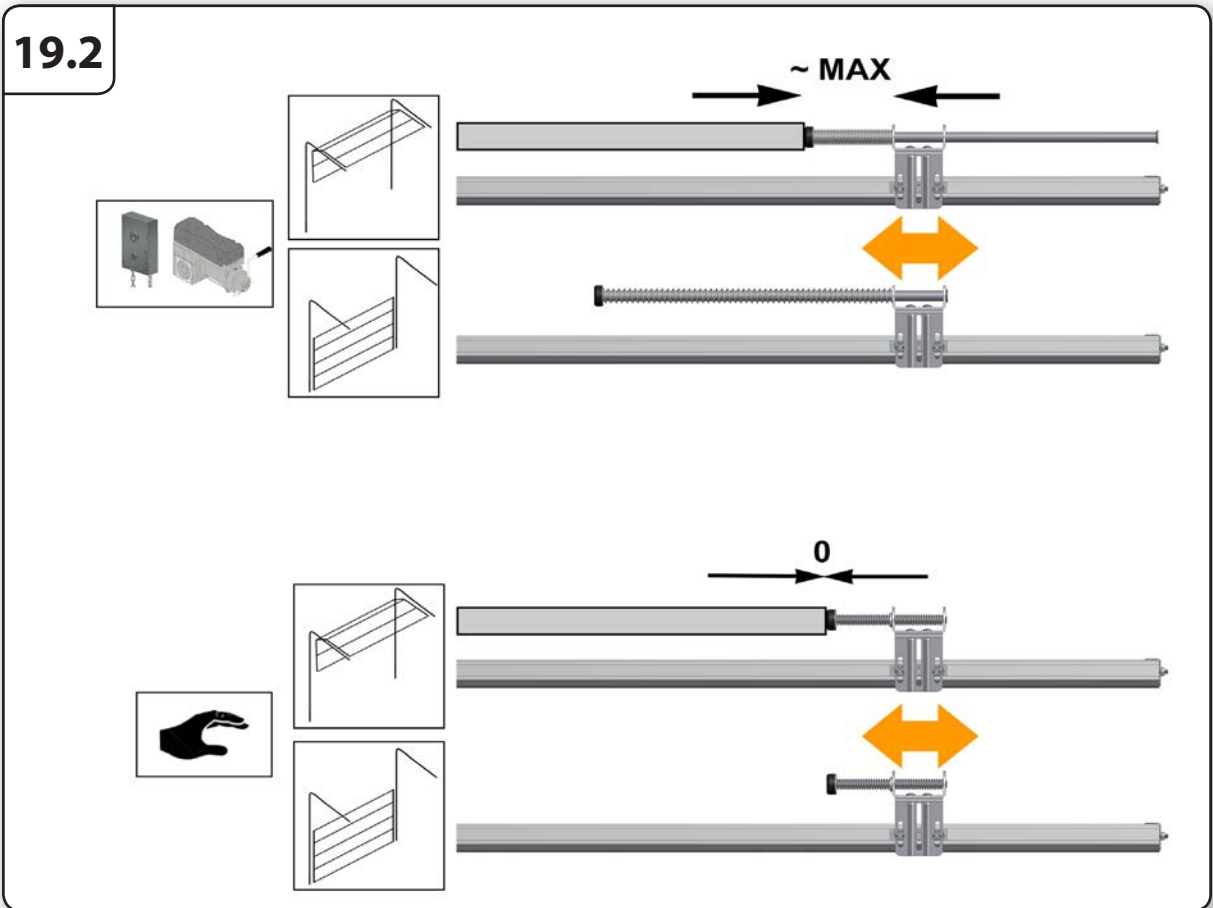

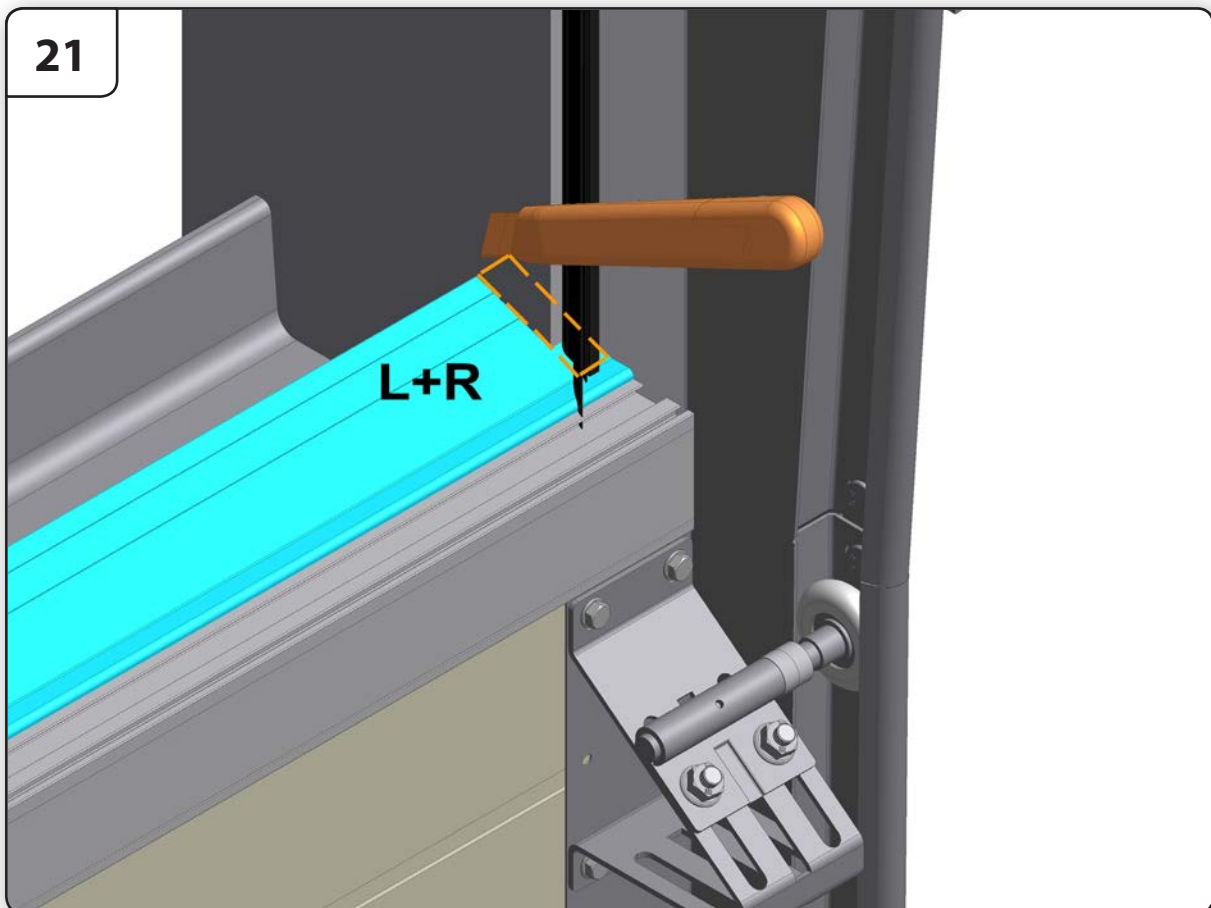
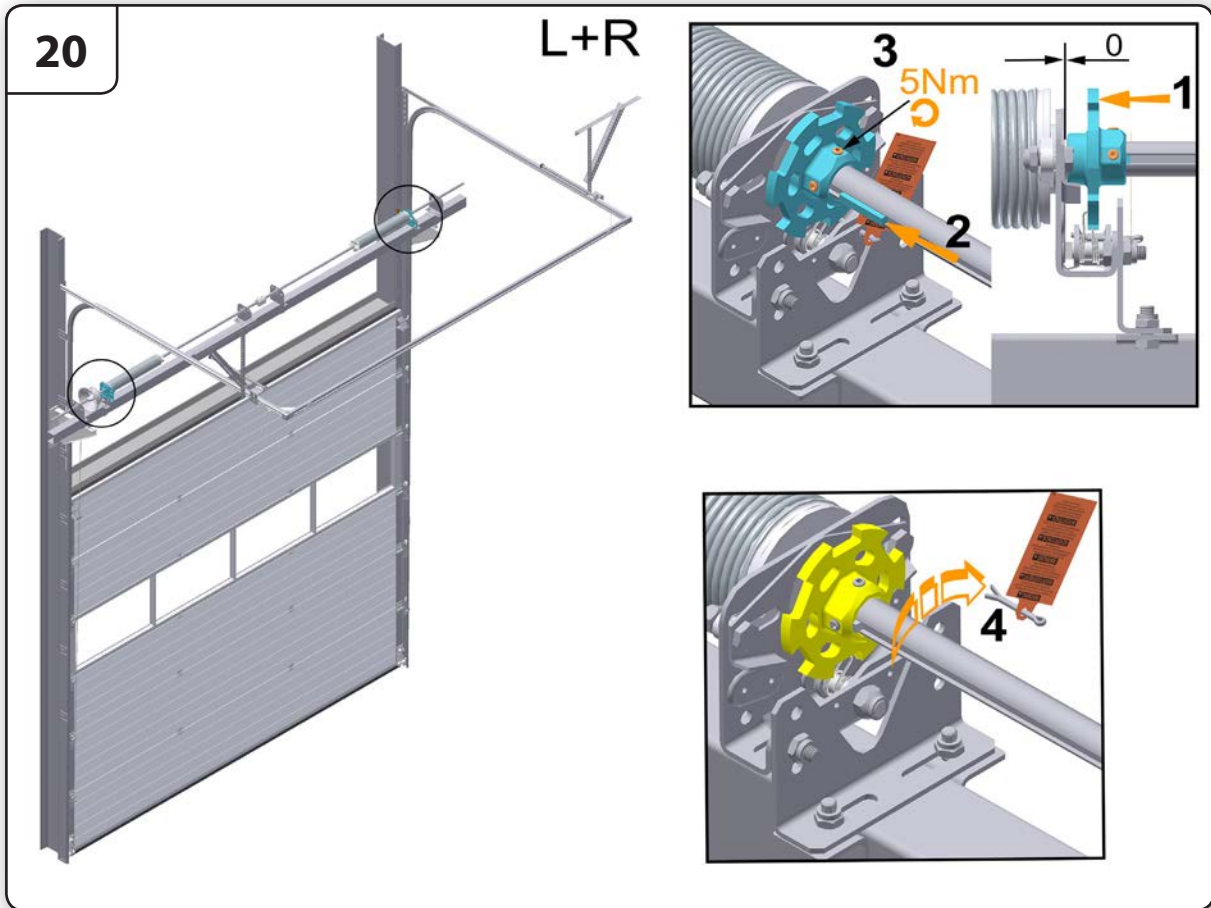

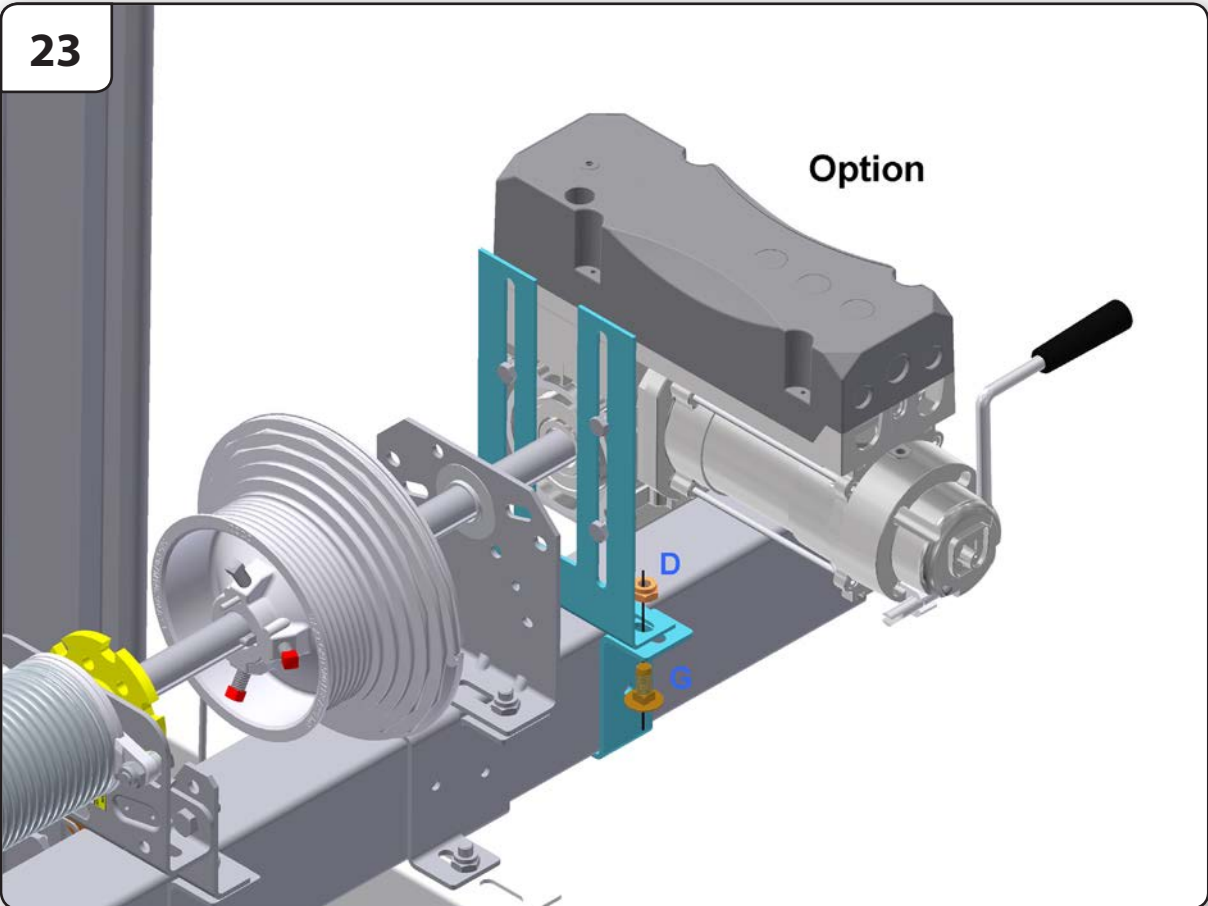
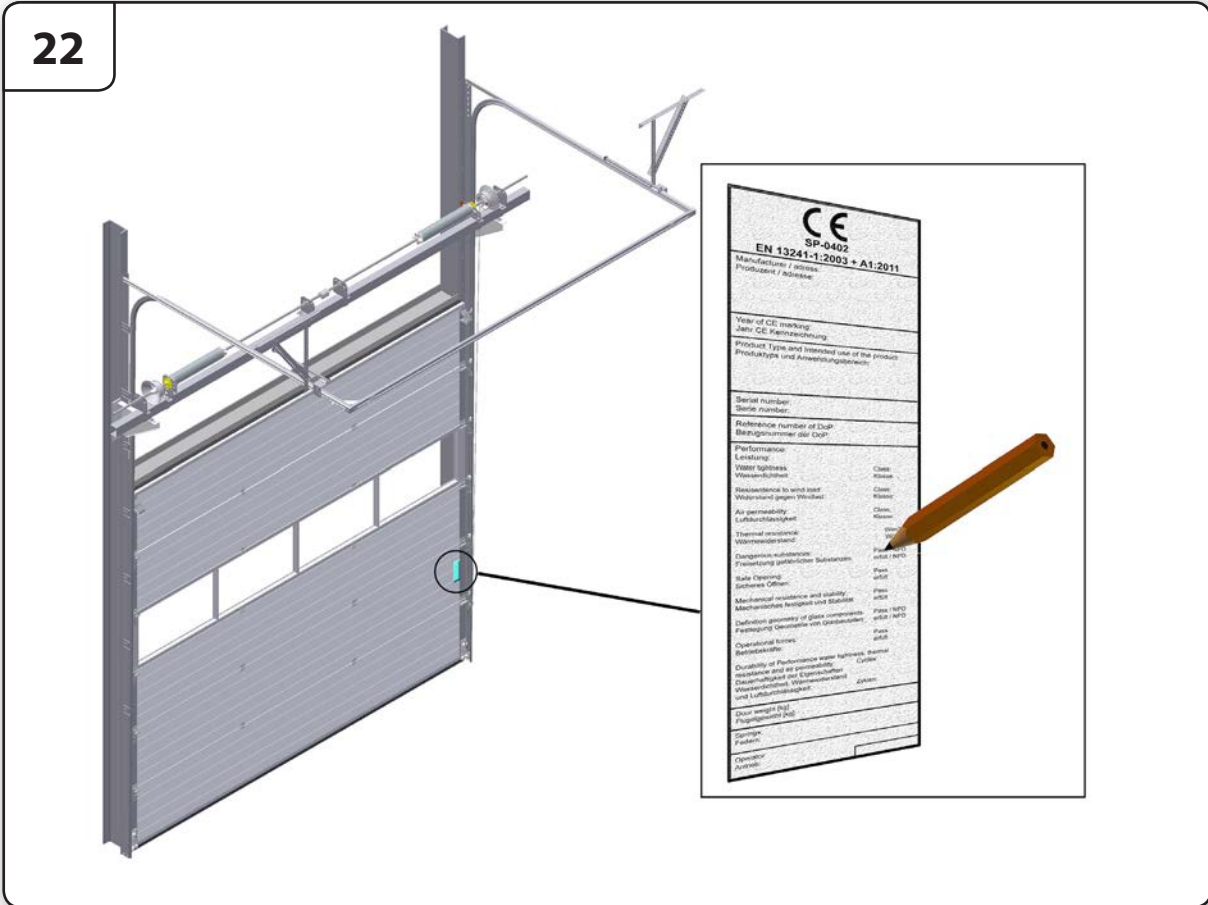

## First use

The First use of the Industrial door System has to be carried out by the installer. After that the ALL users need to be instructed. For more information check the User Manual.

## Handover

Handover the following documents to the end user:

- This manual (assembly, maintenance and disassembly)
- User manual
- Service logbook
- Declaration of Performance (DoP)
- Declaration of Conformity (DoC), only in case of a Power operated door

## Electric operator (optional)



Mount the operator according the supplier's manual.

### NOTE:

In case of power failure it should be possible to unlock the door using the emergency release from the operator. The door leaf may only in that case, be operated with a handle. Do not fit a pull cord, shoot bolt or lock to an electrically operated door, or the shootbolt or lock need to be equipped with a E-switch.

## Control unit settings

Settings to the control unit should be carried out in accordance with the operator manufacturers manual.

Please note that our hardware kits have been CE approved for use with the operators specified in our ITTr report. Should a different operator be chosen, then the installer must carry out a peak force analysis in accordance with EN-12445 and EN-12453.

## Disassembly



**Disassembly should be only carried out by an qualified industrial door company / installer.**

The door should be disassembled in the reverse sequence to the assembly manual.

## Warnings



- Brackets and other components which are attached to Torsion Springs and Cables are under extreme tension.
- Tensioned springs carry a high tension; always be very careful, and make sure the tensioning bar (# 12025) are well maintained and use the right side of the bar (depends on used spring plug).
- When checking the industrial door system, always disconnected the electrical main power supply and make sure that it is blocked against re-engaging without you knowing it.

## Procedure:

- 1 Release tension of the torsion springs!
  - a) Insert the 1<sup>st</sup> tensioning bar into the tensioning head
  - b) Keep a good grip on the 1<sup>st</sup> tensioning bar and carefully undo the bolts on the tensioning head and transfer the spring tension.
  - c) Now place the 2<sup>nd</sup> tensioning bar in the next hole of the spring plug and carefully release the spring. The spring is released from top to bottom.
  - d) Again, fit the 1<sup>st</sup> tensioning bar to the spring plug and release.
  - e) Repeat steps 3-4 until the spring is released.
  - f) Repeat steps 1-4 for the other spring (springs).
- 2 Remove the electrical operator, according the manual of the electrical operator
- 3 Release the bolts in the cable drums and remove the steel cables from the cable drums. Be careful for any remaining tension in the cables, check if the cables are slack!
- 4 Remove the power-unit. Do this by first removing the coupler and then carefully sliding both shaft halves out of the bearing plates. Be aware that components may slide along the shaft!
- 5 Remove the panel sections from top to bottom. Achieve this by removing the roller holders and centre hinges.
- 6 Remove the horizontal trackset
- 7 Remove the vertical trackset

## Disposal

All parts of this Industrial Door System can be easily disposed of. Please consult your local authorities on this matter.

## Maintenance



In accordance with EU standards, Industrial door systems should be maintained and checked regularly, from the first time of use, based on the indicated service by the installer.

Maintenance needs to be recorded written.

**Maintenance should be only carried out by an qualified industrial door company / installer.**

## Warnings

- Brackets and other components which are attached to Torsion Springs and Cables are under extreme tension.
- Tensioned springs carry a high tension; always be very careful, and make sure the tensioning bar (# 12025) are well maintained and use the right side of the bar (depends on used spring plug).
- When checking the industrial door system, always disconnected the electrical main power supply and make sure that it is blocked against re-engaging without you knowing it.

### Directly after installation (By Installer):

- 1 Lubricate the running part of the tracks (advice: PTFE)
- 2 Lubricate bearings and the shaft of the rollers (advice: PTFE)
- 3 Lubricate pins of the hinges from intermediate- and side-hinges (advice: PTFE)
- 4 Lubricate the bearing of the shaft (advice: PTFE)
- 5 Lubricate sealing rubbers (advice: special rubber grease or vasaline)

### After 3 months (By Installer):

- 1 Check balancing system / Re-tensioning springs (relaxation springs)
- 2 Complete visual inspection

### Every 6 months (By User):

- 1 Check side seals, Top seal and Bottom Seal on damage or wear and tear
- 2 Lubricate the running part of the tracks (advice: PTFE)
- 3 Lubricate bearings and the shaft of the rollers (advice: PTFE)
- 4 Lubricate pins of the hinges from intermediate- and side-hinges (advice: PTFE spray)
- 5 Lubricate sealing rubbers (advice: special rubber grease or vasaline)
- 6 Clean the panels (advice: shampoo for car cleaning with water), do not use aggressive detergents
- 7 Wax the panels (advice: car wax)
- 8 Remove dirt from the door and surroundings

### Every 12 months or every 7500 door cycles (By Installer):

- 1 Check the cables and the end connections from the cable on damages or wear and tear
- 2 Check the cable connection points on bottom bracket or cable break device and Cable drum
- 3 Check the spring break devices in accordance with separate manual
  - 3.1 Check the position of the ratched wheel
  - 3.2 Check the function of the catcher
- 3.3 Check the bolt and screws connection of the SBD
- 4 Check the Cable Brack Device in accordance with the seperate manual
  - 4.1 Check the function of the Cable Break Device
  - 4.2 Check position of the knife of the Cable Break Device
  - 4.3 Check the position of the hinge pin
- 5 Check the balance of the door and adjust if needed / check the manual operation
- 6 Check the hinges on breaking and wear and tear
- 7 Check the Pulley system (if present) for damages or wear and tear
- 8 Check or test the fixations of the springs to the spring plugs
- 9 Check the rollers or damages or wear and tear and free moving space
- 10 Check the closing forces of the main closing edge (Only if Electrical Operation an Not Deadman function)
- 11 Check the suspension from the horizontal track to the ceiling
  - 11.1 Check the suspension profiles on breaking or damages
  - 11.2 Check the bolt and nut connection
- 12 Check side seals, Top seal and Bottom Seal on damage or wear and tear
- 13 Check the panels on damage, wear and tear
- 14 Lubricate torsion springs, bearings of rollers, running parts of the track and bearing on the shaft

**Every 24 months or every 15000 door cycles (By Installer):**

- 1 Check the cables and the end connections from the cable on damages or wear and tear
- 2 Check the cable connection points on bottom bracket or cable break device and Cable drum
- 3 Check the spring break devices in accordance with separate manual
  - 3.1 Check the position of the ratched wheel
  - 3.2 Check the function of the catcher
  - 3.3 Check the bolt and screws connection of the SBD
- 4 Check the Cable Brack Device in accordance with the seperate manual
  - 4.1 Check the function of the Cable Break Device
  - 4.2 Check position of the knife of the Cable Break Device
  - 4.3 Check the position of the hinge pin
- 5 Check the balance of the door and adjust if needed / check the manual operation
- 6 Check the hinges on breaking and wear and tear
- 7 Check the Pulley system (if present) for damages or wear and tear
- 8 Check or test the fixations of the springs to the spring plugs
- 9 Check the rollers or damages or wear and tear and free moving space
- 10 Check the closing forces of the main closing edge (Only if Electrical Operation an Not Deadman function)
- 11 Check the suspension from the horizontal track to the ceiling
  - 11.1 Check the suspension profiles on breaking or damages
  - 11.2 Check the bolt and nut connection
- 12 Check the shaft on damages and wear and tear
- 13 Check the connection of the trackset
- 14 Check and re-fix the bolt of the coupler
- 15 Check side seals, Top seal and Bottom Seal on damage or wear and tear
- 16 Check the panels on damage, wear and tear
- 17 Lubricate torsion springs, bearings of rollers, running parts of the track and bearing on the shaft

## Replacements of Parts

**Only use Original DOCO spare parts!****Maintenance should be only carried out by a qualified industrial door company / installer.****After Spring Break:**See instructions separate manual (or download the manual: [www.doco-international.com](http://www.doco-international.com))

- 1 Replace the springs and the Spring Break Device
- 2 Check the shaft on damages and replace if necessary

**After Cable Break:**See instructions separate manual (or download the manual: [www.doco-international.com](http://www.doco-international.com))

- 1 Replace cable with connection
- 2 Replace the complete Cable Break Device
- 3 Check tracks and service or replace the tracks

## Supplier

DOCO International b.v.  
 Nusterweg 96  
 6136 KV Sittard  
 P.O. Box 427  
 6130 AK Sittard  
 The Netherlands  
 Tel: +31 (0) 464200666  
 Fax: +31 (0) 46452894  
[www.doco-international.com](http://www.doco-international.com)



**DOCO International B.V.**

Nusterweg 96  
6136 KV Sittard  
The Netherlands  
Phone +31 464200666  
Fax +31 464526894  
info@doco-international.com

**DOCO International  
Southern Europe S.L.U**

Avenida Generalitat 55  
P.I. "Can Met Sidru"  
08530 La Garriga - Barcelona  
Spain  
Phone +34 938612825  
Fax +34 938716592  
ventas@doco-international.com

**DOCO International  
Central Europe S.R.O.**

Háj 352  
798 12 Kralice na Hané  
Czech Republic  
Phone +420 582360100  
Fax +420 582360300  
info@doco-international.com

**DOCO International Ltd.**

Unit B3. Elvington Industrial Estate  
Elvington  
York  
YO41 4AR  
United Kingdom  
Phone +44 1904607869  
Fax +44 1904607299  
sales@doco-international.co.uk

For your Residential  
and Industrial door solutions:

[www.doco-international.com](http://www.doco-international.com)

A company of the SOMMER Group

